

Expedient Homemade Firearms

Volume II

**The
.32/.380
Machine
Pistol**

**Including
*The 9mm
Machine
Pistol***

*A
Manual
For
Independent
Gunsmiths*

P. A. Luty

Expedient Homemade Firearms:

The Machine Pistol

By P. A. Luty (D.F.C)

Copyright C.2004 by P. A. Luty

A Home-Gunsmith Publication

All rights reserved. Anyone attempting to reproduce any part of this publication in any form without the express written permission of the author will be tried, sentenced and shot, (and not necessarily in that order)

Printed in England by ***Bunker Books Inc;***

Direct all enquiries to:

www.thehomegunsmith.com

Neither the author nor publisher assumes any responsibility for the use or misuse of the information contained in this book.

For academic study purposes only.

'Gun control' has had a long history:-

“The people of the various provinces are strictly forbidden to have in their possession any swords, bows, spears, firearms, or other type of arms. The possession of these elements makes difficult the collection of taxes and dues and tends to permit uprising, therefore, the heads of the provinces, official agents, and deputies are ordered to collect all weapons mentioned above and turn them over to the government.”

Toyotomi Hideyshi, Shogun, August 29, 1558

CONTENTS

Foreword	1
Introduction	2
Tools Required	4
Buying materials	5
Tubing and materials required	6
Specifications	7

CHAPTERS

1. Lower Receiver Construction	9
2. Grip and Magazine Well	15
3. Magazine Construction	21
4. Trigger and Guard	31
5. Sear Construction	33
6. Upper Receiver	41
7. Barrel Assembly	49
8. Breech Block Assembly	53
9. The Ejector	59
10. Mainspring, Guide and Recoil Shield	61
11. Assembling the Machine Pistol	67
12. Making a Sling	71
13. Final Finishing	73
14. Test Firing	75
APPENDIX A : Machine Pistol Tube Sizes	77
APPENDIX B : Tube Sizes for Improvised Barrels	79
APPENDIX C : Chamber Reamer Suppliers	81
APPENDIX D : Homemade Reamer	83
APPENDIX E : .380 Conversion	87
APPENDIX F : Machinist Drawings	89

FOREWORD

So, you would like to know how a homemade firearm is constructed, what types of materials are used, and what tools are required to build the gun?

I don't blame you. It is an interesting subject, but more importantly, a useful knowledge to have, especially in these days of increasingly oppressive anti - gun laws. Perhaps this is the first book you have read on the subject, or maybe you have purchased other "Homemade Firearm" publications only to be disappointed and bamboozled by pictures of an engineer or professional Gunsmith building a gun using a lathe and milling machine! The gun made by the man who possesses such equipment is still technically a "Homemade Firearm" because it was made in the home environment; however, relatively few people have access to such equipment. For most people the term "Homemade gun" conjures up the image of a crude looking makeshift contraption, held together with sticky tape and glue, more of a danger to its owner than any potential target!

The true homemade firearm does not have to fall into either of the above categories. It is perfectly possible to construct a firearm without a degree in engineering, and one which you would not be ashamed of admitting to building.

The Expedient Homemade Firearm strikes a happy balance between these two extremes of construction technology.

When the term 'expedient' is used to describe the construction of a given product, it describes something that can be made with relative speed and using the best materials available in any given time or place.

The Expedient Homemade Firearm adheres to both these principles. It is durable, relatively quick to build, does not require the use of special tools and is constructed from the best off-the-shelf materials available.

Expedient is, therefore, the key word when discussing the subject of the home built firearm.

INTRODUCTION

In this volume of Expedient Homemade Firearms i will endeavour to show how a more compact and lightweight machine pistol can be constructed from readily available off-the-shelf materials.

In these days of anti-gun laws, when firearms may have to be hidden away, the more compact and concealable a weapon is the better.

The expedient machine pistol is a .32/.380 calibre weapon. The true expedient firearm is built from the position that no outside influences such as machine tools or professional gunsmith's materials are available. For this reason nearly all major component parts of the weapon, receivers, barrel, breech block and magazine, are constructed from readily available steel tubing, eliminating any need for a lathe. The barrel, for example, is assembled from a length of seamless hydraulic tube reinforced with a series of steel collars and is smooth-bore rather than rifled. While the accuracy available from the smooth-bore barrel is restricted to relatively close ranges, the relative ease and speed of assembling the expedient barrel more than compensates for this necessary compromise.

Manufacturing a gun magazine using the conventional methods of folding sheet steel around a form block can be tricky and a time-consuming process. The expedient magazine avoids these problems, as once again it is constructed of tube and only requires a hacksaw, file, and silver solder to assemble it. The magazine is of a single stack design holding 16 rounds. This is less than the capacity of the commercially produced twin stack design, but again, the relative simplicity of manufacture more than compensates for the reduced capacity.

Certain parts of the machine pistol, such as the sear, require the use of hardened steel. For this reason, I have incorporated certain off-the-shelf products into the gun design that are as close to the correct steel types requires as possible. This eliminates the acquisition and heat treatment of specialised steels which can pose a problem.

I have not included any sights on the machine pistol as they would only be for cosmetic purposes, rather than to make the gun more accurate.

The machine gun is primarily a point and fire weapon. Reliability and simple functionality are the main priorities, especially for a weapon that should be kept as simple as possible. In short, I have included only what is necessary to ensure the gun will function as reliably as can be expected.

It should be noted that the life expectancy of any firearm built using the type of materials and techniques illustrated in this book will be less than that of one built from the correct steels and to machine tool tolerances. However, due to the ease with which parts,(such as the breech block and barrel) can be made; it is possible to keep the firearm in permanent working order by having a selection of spare parts available and ready for use. A spare breech block and barrel should be regarded as a necessity.

WARNING

THE MATERIAL PRESENTED IN THIS BOOK REPRESENTS THE AUTHORS ATTEMPTS AT DEVELOPING AND BUILDING HOMEMADE FIREARMS AND DOES NOT NECESSARILY CONDON OR ENCOURAGE THE CONSTRUCTION OF FIREARMS BY ANY INDIVIDUAL OR GROUP.

THE CONSTRUCTION OF FIREARMS IN MOST JURISDICTIONS IS ILLEGAL. NEITHER THE AUTHOR NOR PUBLISHER ASSUMES ANY RESPONSIBILITY FOR THE USE OR MISUSE OF THE MATERIAL PRESENTED IN THIS PUBLICATION. THE TECHNICAL DATA PRESENTED, PARTICULARLY ON THE USE OF FIREARMS, INEVITABLY REFLECTS THE AUTHORS INDIVIDUAL EXPERIENCES WITH PARTICULAR FIREARMS UNDER SPECIFIC CIRCUMSTANCES WHICH THE READER CANNOT DUPLICATE EXACTLY. THE MATERIAL SHOULD, THEREFORE, BE TREATED AS ACADEMIC STUDY MATERIAL ONLY AND APPROACHED WITH CAUTION. THE COMPLIANCE WITH ANY LAW IS THE SOLE RESPONSIBILITY OF THE INDIVIDUAL READER.

TOOLSREQUIRED

1. Electric Drill or Drill Press
2. Drill Bits 1.5 to 9mm diameter
3. Hacksaw
4. Large Files, Round, Half Round and Flat
5. Angle Grinder
6. Bench Grinder
7. Hammer
8. Set square
9. 14.2 mm (9/16) Taper Pin Reamer
10. Taper Cutting Tool
11. Countersink Tool
12. Large Vice

The tools listed above are the minimum required. Obviously the better selection of tools you have at your disposal the easier the firearm will be to construct. A drill press, for example, while not in the hand tool category, will save you a lot of time when drilling holes, etc. It is worth pointing out that a drill press is no more expensive than a good quality electric hand drill and if you are considering buying a new drill, I would strongly recommend a drill press with a minimum 3/8" chuck capacity.

If you have access to a lathe, the need to acquire the tubing for the barrel and breech block will be unnecessary. A lathe is not necessary to construct any part of the firearm featured in this book; I merely point it out in the event of such equipment being available to the reader. The time required to build the machine gun will be dependent partly upon the equipment available to the reader and also upon the general ability of the individual concerned. As a general guide, it should be possible for the average individual to build the entire weapon in a week to ten days, once the necessary materials have been acquired. For the individual who has access to a lathe, the manufacturing time can be halved.

BUYING MATERIALS

As I mentioned earlier, almost the entire weapon is constructed from steel tubing. The best places to look for the type of tubing we require are tube stockholders, who will usually have in stock all the tube sizes required for any construction. It should be noted that tube suppliers usually have minimum order charges. I would advise ordering all tube sizes required for construction at the same time to take advantage of the minimum order charges. Many suppliers also have a tube cutting service so I would strongly suggest having the lengths of tube cut into three foot lengths for easy of handling and storage, etc. For small quantities of tube, engineering and steel fabrication shops are a good place to look. However, you will not find all the tube sizes required in such places. A list of tube sizes and materials required are supplied overleaf. I have marked the occasional item with a (*) to indicate that several of that particular item should be purchased in case of mistakes during manufacture.

For items such as shaft lock collars, mud wing washers, hexagonal keys/wrenches, socket screws etc, look in the Yellow Pages under "Nut and Bolt" and "Engineering Supplies" for a stockist near you. It is very unlikely your local hardware shop will stock the items required, and a trip to the correct supplier will be a necessity. Spring steel strip material and spring wire (piano/music wire) is available from any good model engineering shop. Your local spring manufacturer is also a good source for spring wire material.

TUBE SIZES REQUIRED

1. 30 x 30 x 2mm Upper Receiver
2. 30 x 30 x 1.6mm Lower Receiver
3. 14.29 x 3.25mm Barrel (SMT)*
4. 12.70 x 2.03mm Breech Block (SMT/SHT/ERW)*
5. 25.40 x 12.70 x 1.6mm Magazine
6. 12.70 x 0.91mm Magazine
7. 34.93 x 15.88 x 1.6mm Magazine Well
8. 40 x 20 x 1.6mm Grip
9. 50.80 x 1.6mm Trigger Guard

* Seamless mechanical/Seamless hydraulic/Electric Resistance Welded

MATERIALS REQUIRED

1. 3" x 2" x 1/8" Steel Plate (Trigger)
2. 10mm Hexagon Wrench/Key (Sear)*
3. 1/2" Shaft Lock Collars x 14
4. 5 and 6mm Shaft Lock Collars x 2
6. 5.5mm dia' Steel Rod x 24" long (or 7/32")
7. 19.05 x 5mm Flat Bar x 25" long (or 3/4 x 3/16)
8. 3mm dia' Steel Rod x 5 1/2"long (or 1/8")
9. 9.5 x 1.6mm Steel Strip (Sheet) x 6" long (or 3/8"x 1/16")
10. 19.05 x 9.5mm Flat Bar x 9" long (or 3/4 x 3/8")
11. 20 Gauge Piano Wire (Music Wire) Purchase several rolls
12. 18 Gauge x 7/16" Spring Steel Strip, 12"long
13. 20 Gauge x 1/2" Spring Steel Strip, 8" long
14. 6mm dia' Socket Screws (x 11) 9mm long (or 1/4" x 3/8")

SPECIFICATIONS

<u>Weapon Type</u>	<u>Machine Pistol</u>
<u>Calibre</u>	<u>.32/.380</u>
<u>Capacity</u>	<u>.32 (15) .380 (14)</u>
<u>Overall Length</u>	<u>18 $\frac{3}{4}$"</u>
<u>Barrel Length</u>	<u>9"</u>
<u>Weight Unloaded</u>	<u>4 lbs 8 oz</u>
<u>Sights</u>	<u>None</u>
<u>Construction Materials</u>	<u>Tube, Collars, Nuts and Bolts</u>
<u>Material Availability</u>	<u>Good</u>
<u>Tools Required</u>	<u>Hand only</u>

“DESIGNANDDEVELOPMENT”

I am often asked questions, by readers of my books, about design and development issues. A question I often hear is, “Do your gun designs actually work”? I am even sent “design improvement” drawings occasionally, by well meaning would-be gun designers!

The reader should be aware that the weapons shown in this publication *do* work, in that, they can throw ammunition “down range” at an alarmingly expensive rate! The reader, however, should also be aware that due to personal circumstances, and the fact that building guns is completely *illegal*, little time was lost in the “design and development” stage. The gun designs *can*, therefore, be improved upon in areas such as aesthetics, compactness of design and components, and materials used in construction etc. Despite this, I hope I have lead the way in a particular area of gun design, making it easier for other “homemade gun” designers to follow, and perhaps improve upon what I have done!

1

LOWER RECEIVER

We will start building the machine pistol by first constructing the lower receiver. This is probably the best place to start because the lower receiver accepts most of the guns working parts i.e. the trigger mechanism and magazine.

The lower receiver is cut out, using a hacksaw, from an 11 1/8" length of 30 x 30mm 16 gauge box section steel tubing. A heavier gauge may be used up to a wall thickness of 2mm, but in the interest of keeping the weapon as light as possible, the 16 gauge (1.6mm) tube is best. First, cut the tube to a length of 11 1/4", slightly longer than the 11 1/8" length required. Use a 'set square' to ensure both ends of the tube are straight, then wash the tube in warm soapy water to ensure it is thoroughly clean. Various recesses must be cut into the tube, and to make this process as quick and simple as possible, I have supplied two scale templates, (See Figure A). The template sheet should be traced, or quicker still, photocopied onto an A4 size sheet of paper or card. Make several copies, just in case a slip of the knife occurs during cutting out.

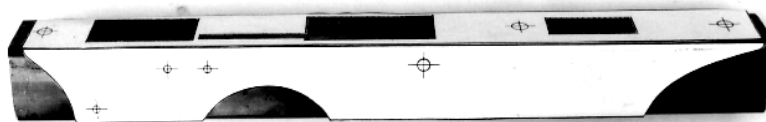

Lay the copied template sheet on a flat surface and, using a sharp craft knife, cut out both templates. The three shaded areas on template No1 are also removed as carefully as possible. It is a good idea to use a ruler to guide the knife, to make cutting out as accurate as possible. Both templates are now glued to the receiver tube, as shown below. Check that the templates are in as exact an alignment with the tube as possible, before marking the position of each recess and contour onto the tube. A scribe or other sharply pointed tool is used for this procedure. The six crossed circles indicate the positions of the various holes that must be drilled into the tube, and these positions must be marked also. This is accomplished by placing a punch, (sharp nail, etc) in the centre of each cross mark and tapping the punch firmly with a hammer to transfer the position of each hole through the template and onto the tube. Before removing the templates, check that each score line is clearly visible; then remove the templates. With the tubing clearly marked out we can start to cut out the lower receiver. First, the side contours of the receiver must be shaped, as indicated by the score lines from template No2. A hacksaw and a large half round file is all that is required to achieve this. The ends of the tube are shaped first, by removing most of the metal with a hacksaw, then carefully filing each end to shape.

Lower Receiver Construction

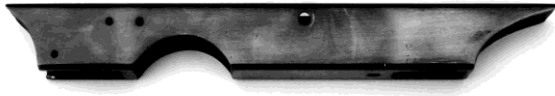

Photo 2: Side view of upper receiver after cutting out.

The arched section next to the three crossed circles (now punch marked) is the trigger guard recess. Make a saw cut at each end of the guard recess marks, and saw to the top of the arch, both saw cuts making a 'V' shape. A large half round file, ideally 1½" to 2" across, is now used to trim the recess to its correct curved shape. Remember, you are sawing through a tube, so both sides must be shaped as close to the same dimensions as possible, (*Photo 2*). Next, we will drill the holes through the side of the receiver. The three holes at the rear of the receiver are made with a 4mm drill, and the single hole near the middle of the receiver is drilled to a diameter of 5mm. The four holes will eventually accept the grip retaining pins and the trigger and sear pivot bolts. Obviously, the holes are drilled through the receiver from one side to the other, so try to keep the drill as near to a right angle as possible to ensure each side is the same. If a drill press is used, then the accuracy of each hole is ensured. The three recesses that will eventually accept the grip, trigger, sear and magazine well, can now be cut into the top of the receiver to the dimensions left by template No1. It is not

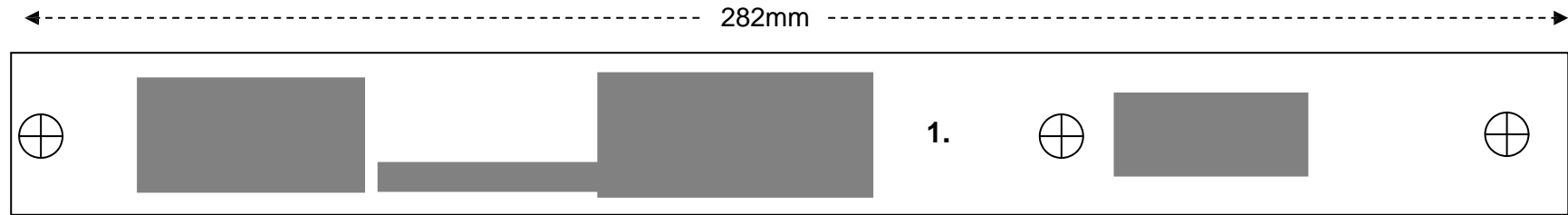

Photo 3: Top view of upper receiver showing recesses.

possible to remove the unwanted sections with a hacksaw so a series of interconnecting holes, around 3mm in diameter, must be drilled along the inside edge of each score line. Use a good sharp drill bit for this procedure and it can be done surprisingly quickly. With the holes drilled, place a flat ended punch, such as a short length of rod, on the sections to be removed and hit the punch sharply with a hammer. The unwanted metal will break away and can be removed. The jagged edges of each recess can now be filed smooth to the score lines left by the template, (*Photo 3*).

Three 6.5mm holes are now drilled through the top of the receiver, in the positions marked. The hole behind the magazine well recess is an exception though, as it is drilled through both sides of the receiver. The recesses for the grip and magazine well must pass through the receiver from top to bottom. We have already cut the upper recesses with the help of template No1. The position of these two recesses must now be transferred to the underside of the receiver. The lower grip recess is positioned several millimetres further back

FIGURE 'A': LOWER RECEIVER TEMPLATES.



REMOVE SHADED AREAS.

BEFORE TEMPLATE CAN BE USED IT MUST BE ENLARGED BY 25% USING A PHOTOCOPIER. **Note:** Following enlargement by 25% the overall length of the template should be 282mm, as illustrated above. If it is not this measurement the template can be enlarged or reduced as necessary until the correct measurement of 282mm is achieved.

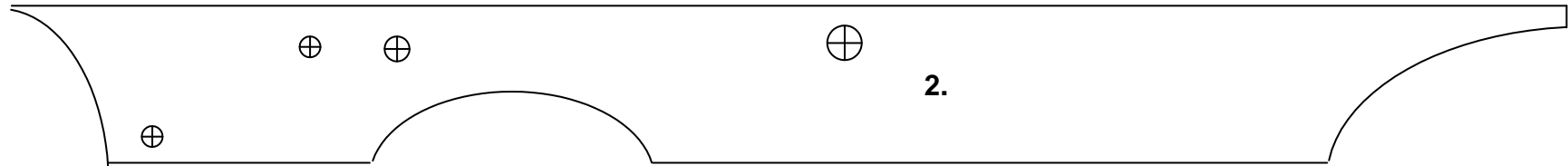

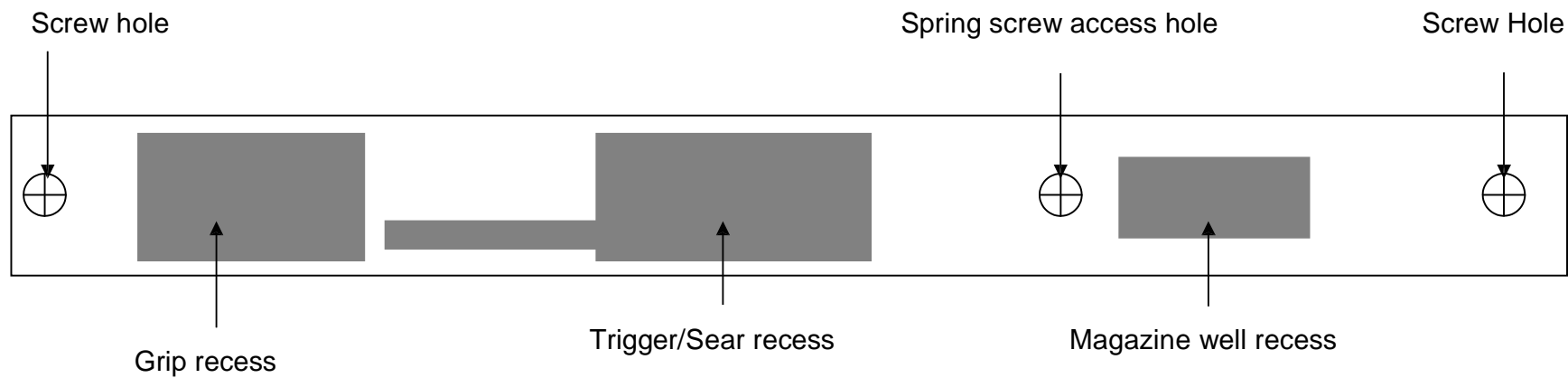

-12-

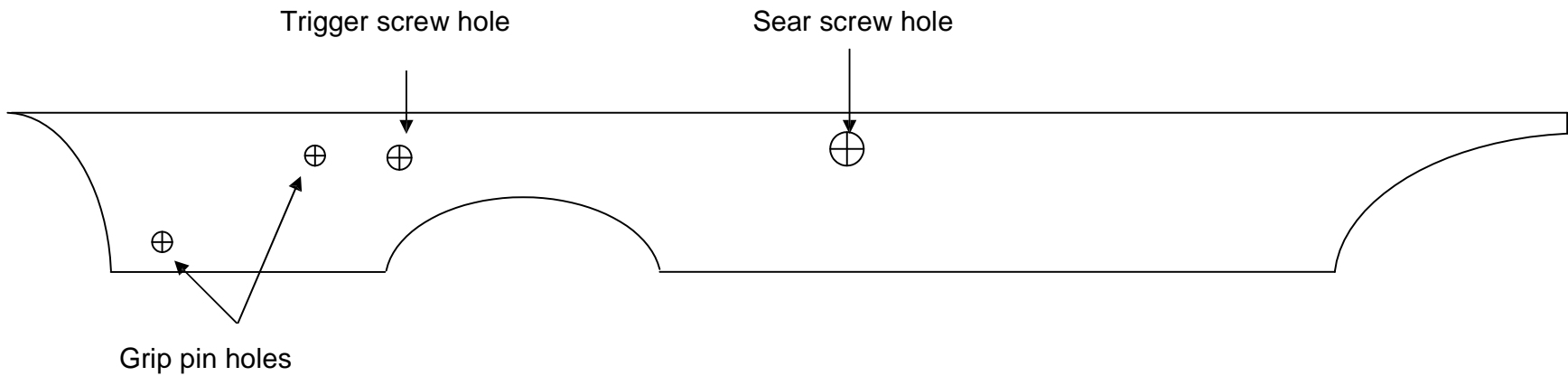

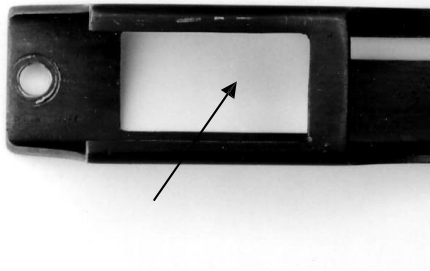

Photo 4: Lower grip recess

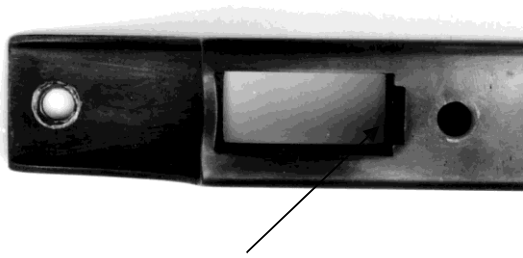

Photo 5: Lower magazine well recess
Note shallow notch (arrowed).

than its upper counterpart. This is to ensure that the grip, when fitted, is at a slight angle in relation to the receiver. Measure in a distance of 41mm from the rear of the receiver and score a straight line, this mark being the length of the recess, (See Figure B). The recess width is 20mm, just the same as its upper counterpart. Remove the unwanted metal using a hacksaw and file to shape, (Photo 4).

The lower magazine well recess is now cut into the underside of the receiver in exactly the same position as the upper recess. The easiest way of transferring the position of the upper recess onto the underside of the receiver is to score two vertical lines down the side of the receiver. The bottom of each line indicates the

exact position of the lower recess; this can now be cut out. The only difference between the two recesses is that the lower recess has a shallow notch (arrowed) filed into one end. This slot should be 12mm wide x 2mm deep and will accept the magazine spring catch in due course, (Photo 5).

Finally, remove any sharp burrs and edges from the inside of the receiver caused by the drilling and filing. The outside surfaces should be polished smooth using medium grade sandpaper until all score lines have been removed. The lower receiver is now finished and we can proceed to fit all of the guns internal parts mentioned earlier.

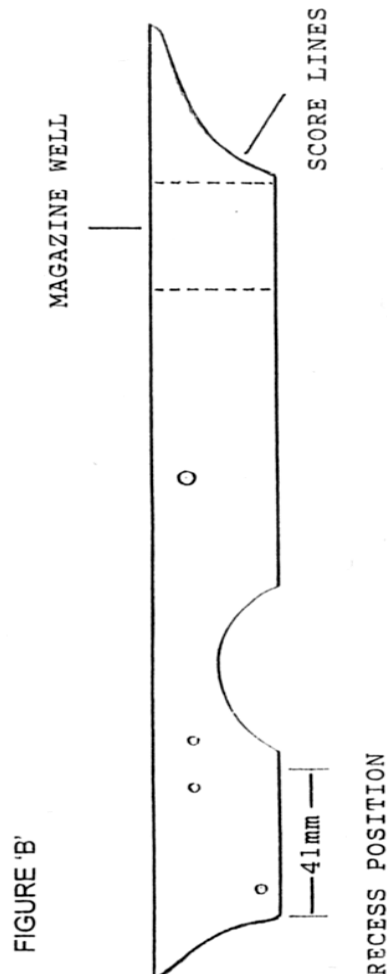

2

GRIP AND WELL



Photo 6: The grip pinned in position

The grip can be fitted first. This part is nothing more elaborate than a length of 40 x 20mm 16 gauge rectangular tube. A slightly heavier gauge can be used, but once again, to keep the weapon as light as possible, 16 gauge is ideal.

Cut each end of the grip at a slight angle. Push the grip into the open-ended lower recess and then up and into the upper recess opening. The top of the grip should be flush with the top of the receiver and a snug friction fit. As with any part, a certain amount of hand fitting may be required before the grip will slide into position.

Two 4 x 30mm spring pins are now used to firmly retain the grip in position. The side of the receiver is already drilled for the pins but the grip is not. Place a 4mm diameter drill bit into each of the receiver grip holes and drill through into the grip. The sides of the grip must be drilled *separately*, do not just drill all the way through the grip from one side to the other or the holes will not line up and the pins will not tap in. Now tap in each pin until they are flush with the side of the receiver, (Photo 6). A grip made from a length of tube in this way is perfectly adequate, and is solid and reasonably comfortable to hold,

The 'magazine well', which is basically a guide tube for the magazine, can now be made and installed. The 'well' is made from a length of 34.93 x 15.88mm 16 gauge rectangular tube. Do not let the rather complicated looking measurement fool you; it is for all practical purposes, nothing more than 35 x 16mm tube. However, when buying the tube, ask for the exact measurement to avoid complications. Unlike the lower receiver and grip, the gauge, (thickness of the tube wall) is very important as the inside dimensions must be correct, and this is governed by the gauge. I have supplied four drawings for the well, 'A', 'B', 'C' and 'D' (See *Figure D*). As shown in Drawing 'A', the well is 114mm in length. First we must cut away a 12mm section from the top of the well so that only the front wall remains, Drawing 'B'. This will be formed later into the cartridge feed

Grip And Magazine Well

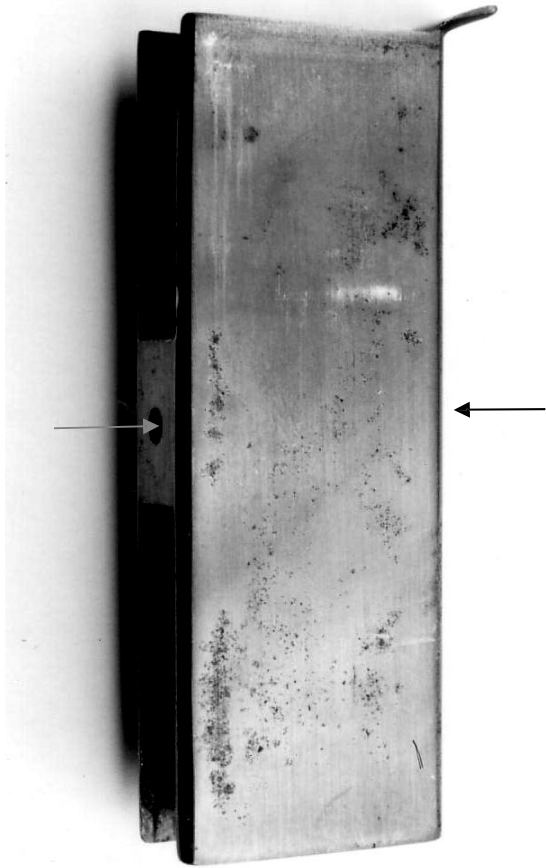

Photo 7: The magazine well showing spring catch recess and rear hole.

ramp, but first, two sections of metal must be cut out and removed from the rear wall of the magazine well to the measurements shown in Drawing 'C'. The width of each recess is governed by the wall of the tube, so only the length measurements need to be supplied. Saw out the unwanted metal using a hacksaw for the lengthways cuts, and then drill a row of four or five holes along the bottom edge of each recess, to allow the sections to be removed. The sides of each recess will be rough and jagged after sawing out and must be filed down to the wall of the well. A 4mm hole is now drilled through the middle of the remaining section of the

rear wall, (arrowed). A corresponding hole, (arrowed), is also drilled through the opposite front wall of the well in alignment with the rear hole, (*Photo 7*). This can be done when making the first hole by simply drilling all the way through the well from one side to the other. All sharp edges from the inside and outside of the magazine well must be removed with a file, so it is completely smooth.

The cartridge feed ramp must be formed to the angle shown in Drawing 'D'. Clamp the well in a vice so the top of the vice jaws are level with the bottom of the ramp. This will ensure that the ramp is easier to form. Place a short section of rod about 4" in length on the top edge of the ramp and firmly tap the rod with a hammer until the ramp is formed to the angle shown in Drawing 'D'. While this drawing is a template, it does not require copying or cutting out. The magazine well can simply be laid over the template until the ramp matches the angle shown in the drawing. Polish the top surface of the ramp and round off the two sharp corners that will be present on its front edges. The purpose of the two recesses and hole cut into the rear of the magazine well are to allow the fitting of the magazine catch spring. The spring has two purposes, to take up excess space in the rear of the well and to hold the magazine in place. It is made from a length of 7/16" x 18 gauge spring steel strip, similar to the material used to make those steel rulers available in most good hardware stores.

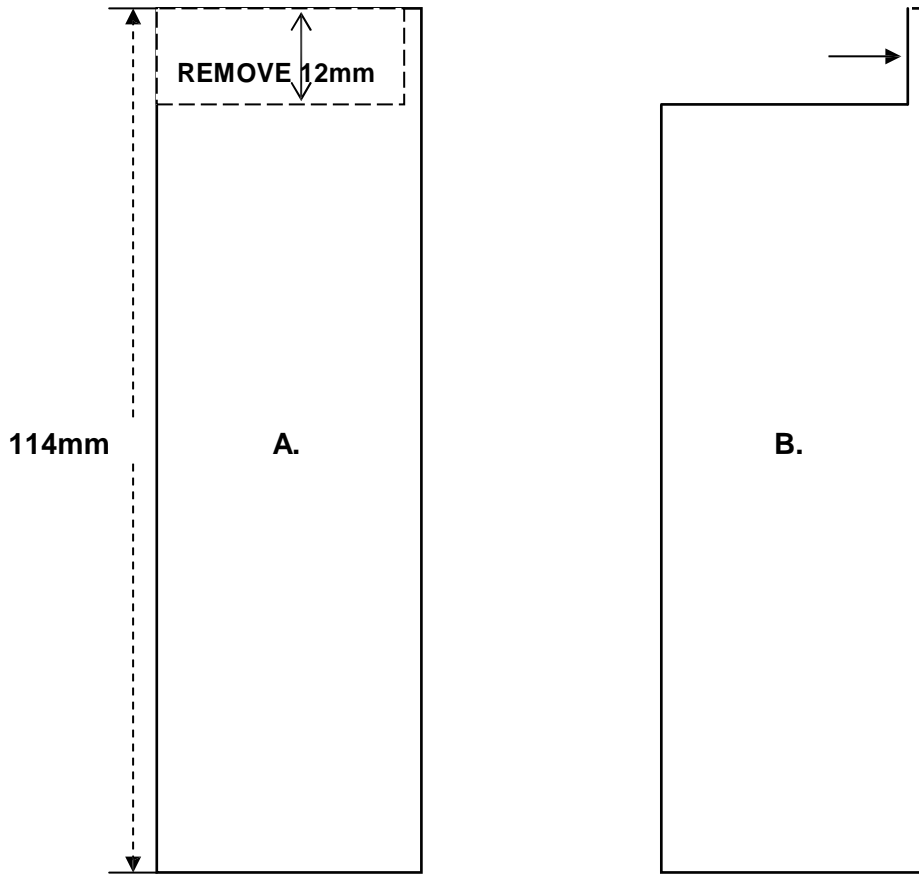
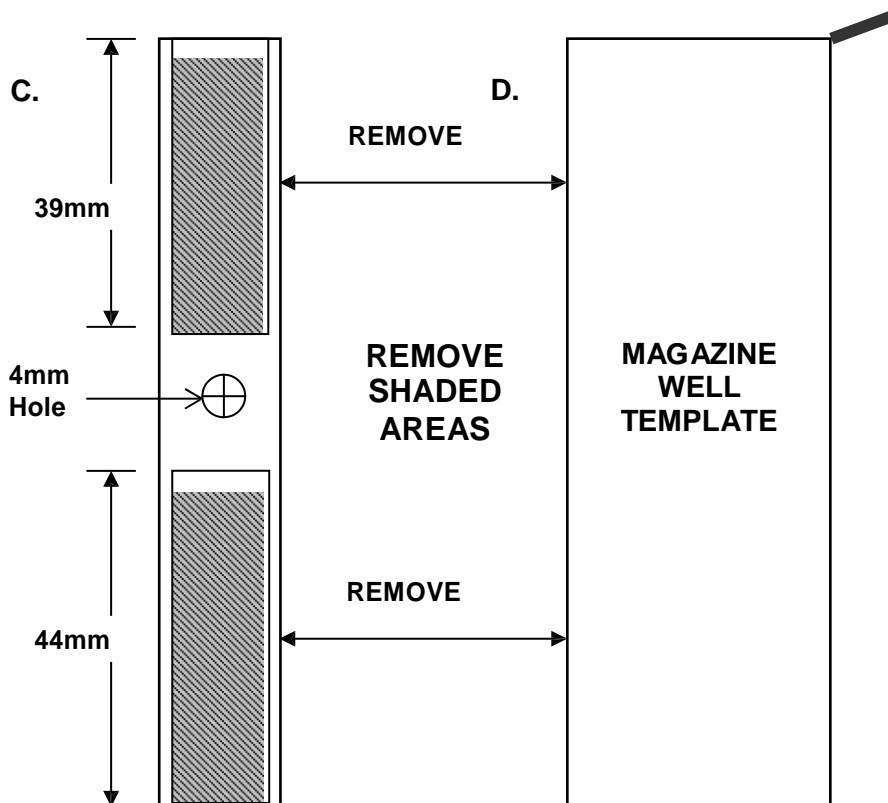

FIGURE 'D', MAGAZINE WELL CONSTRUCTION.



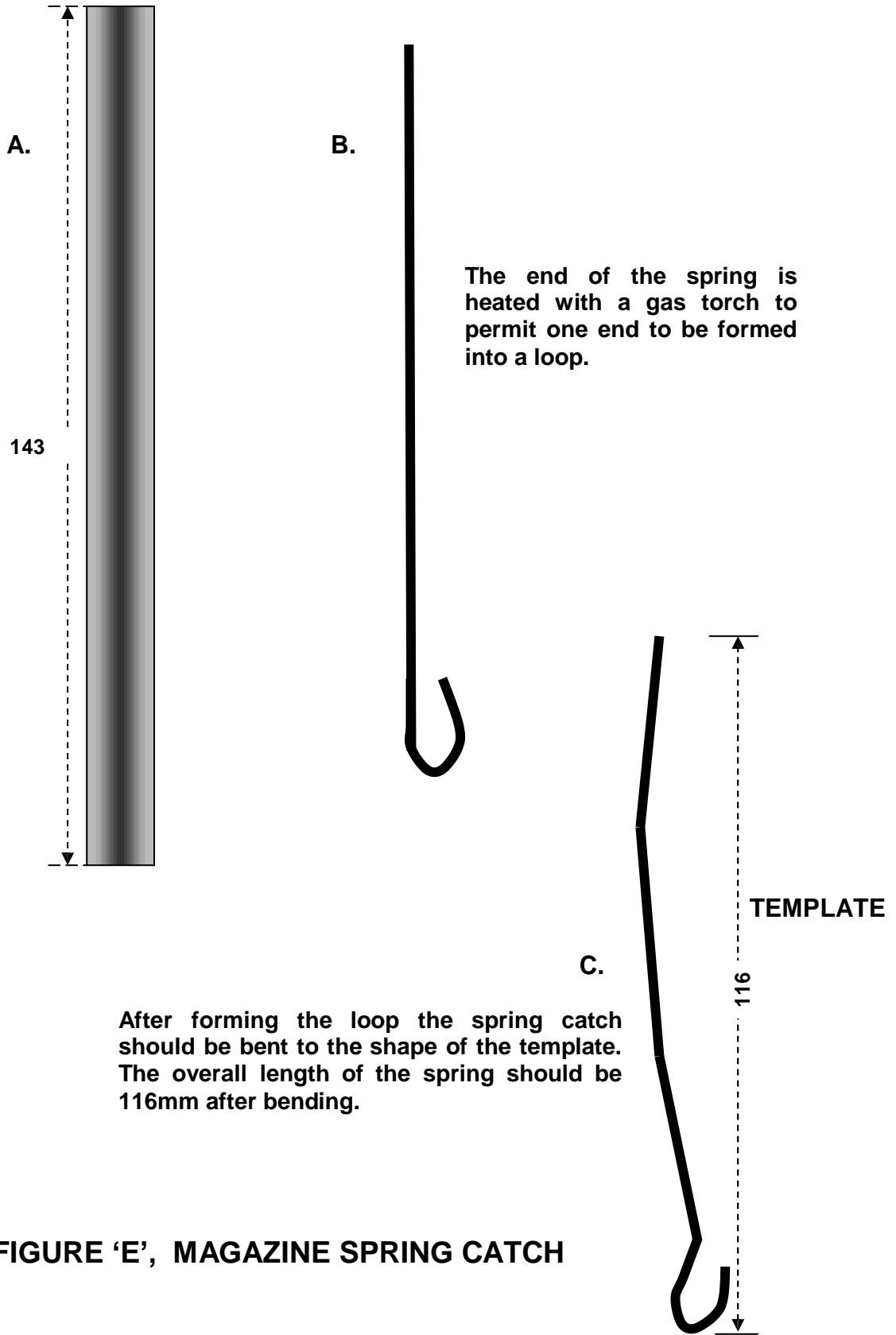

FIGURE 'E', MAGAZINE SPRING CATCH



Photo 8: The magazine spring catch

Spring steel is available in many different gauges and widths, from good model engineering supply shops; the kind of place where builders of model steam engines and the like buy their supplies. I have supplied three drawings to illustrate the correct sequence of forming the spring into its required shape, (See Figure E). Drawing 'A' shows the length of the spring before bending i.e., 143mm. Sawing through spring steel is very difficult due to its hardness, so it is preferable to cut to length using a cutting disc or the corner of a grinding wheel on a bench grinder.

The first step is to form one end of the spring into a loop, as shown in Drawing 'B'. This loop is the section of the spring that acts as the magazine release catch.

Clamp about an inch or so of the spring in a vice so that most of the spring's length is visible. Heat the visible end using a gas torch until about an inch of the spring is glowing a bright red colour. This must be done to make sure it does not break during bending. Hold the spring about half an inch from its end with a pair of pincers and, while keeping the torch flame on the spring, form the loop. Do not quench the spring but allow it to cool slowly. Next, clamp the entire length of the spring in a vice so that just the loop is visible. Bend the loop back slightly until it conforms to the shape of Drawing 'C'. This should be done with the spring cold, it is not necessary to heat the steel again. Remove the spring from the vice and bend the length of the spring into a slight curve, this can easily be done using finger pressure only. The spring catch should now look similar to Template 'C'; it does not have to be a perfect match, but should be reasonably close, (*Photo 8*). Measure the gap at the end of the loop (arrowed), it should measure about 6mm across. Finally, the magazine catch can be fitted to the magazine well. A 4mm diameter hole must be drilled through the spring so it can be bolted to the magazine well. I have not supplied an exact measurement for the position of the hole because you may not bend the spring exactly as I have. Mark the position of the hole by holding the spring against the rear of the magazine well, so a gap of about 6mm exists between the top of the loop and the bottom of the well ('A' - *Photo 9*).

Grip And Magazine Well

Make a mark across the spring in line with the hole we drilled earlier in the rear wall of the well. This is the position at which the hole is to be drilled. Use a 4mm diameter dome head socket screw about 9mm long to retain the spring catch in position, Arrow 'B'. The hole we drilled earlier in the front wall of the magazine well is to allow a hexagon wrench to be inserted into the well to hold the socket screw in position, so the nut can be tightened, Arrow 'C'. The magazine well and spring catch assembly is now finished and ready to be inserted into the magazine well recess.

should be a tight push fit, or at least be snug enough so it will stay in position of its own accord. Position the well so that the top front tip of the feed ramp is 9mm above the top of the receiver. The well will eventually be retained with silver solder but it must remain moveable for now. The spring catch can now be re-attached to the magazine well. When fitted, the top of the spring catch should be about level with the top of the magazine well. Don't worry if it is slightly higher or lower though, as it will not interfere in any way with the functioning of the finished weapon.

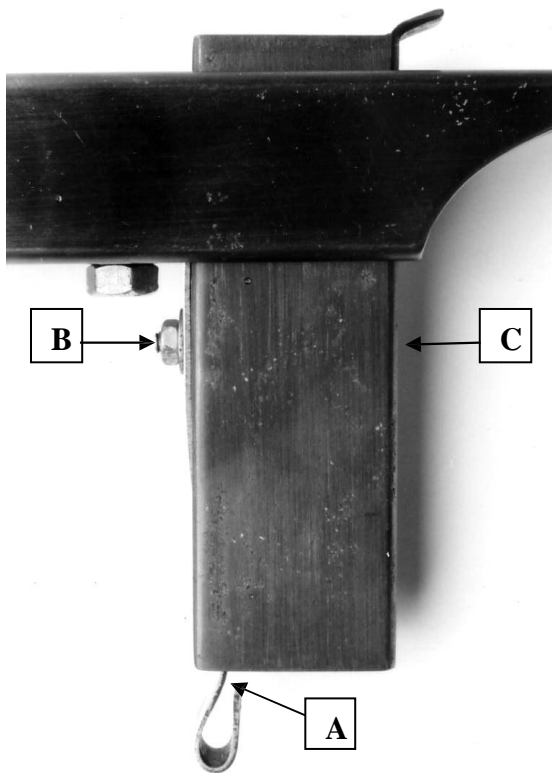

Photo 9: The fully assembled magazine well fitted to receiver.

FITTING THE WELL

The well is pushed into the top of the receiver and down into the lower recess. Before this can be done, the spring catch must be unbolted and removed. The well

3

MAGAZINE CONSTRUCTION

As I pointed out at the beginning of this book, a relatively easy and quick method of building a magazine is to modify a length of tubing, rather than manufacture the magazine from scratch. Unlike the 9mm magazine shown in volume one which was constructed from a single length of tubing, the dimensions of the .32/.380 cartridge require the use of two different tube sizes. The main body of the magazine is a 7 ¾" length of 25.40 x 12.70 x 1.6mm tube, in other words, standard 1" x ½" x 16 gauge. The second magazine tube is a 7 ¾" length of 12.70 x 0.91 mm (½" x 20 g) round tube, (See Appendix 'E' for .380 dimensions).

Both these tubes should be washed so they are thoroughly clean before starting construction. I have supplied seven drawings, 'A' to 'G' (Page 23) to illustrate how the magazine body is assembled (Figure F). The first step is to saw tube 'A' (½" x 20 gauge) in half. It will have to be sawn first from one end and then the other, using a large hacksaw in order to get through the length of the tube. Only one half is required, the other is discarded. File this section down along its entire length as evenly as possible until it is a thickness of 4.5mm, as shown in Drawing 'F'. Remove the top side of the

rectangular (1" x ½") tube as shown in Drawing 'B'. This must be done by sawing down both *side walls*, rather than just sawing off the top of the tube. With the top removed, remove the two jagged edges that will exist on both inside walls due to the sawing procedure. Measure the height of the tube from top to bottom, it should measure 25mm, as shown in Drawing 'D'. Now run a round or half round file back and forth along the tubes open side until a bevel is created, as in Drawing 'E'. The file should be a few millimetres larger than the width of the tube. The two halves are now clamped together with a pair of hose clips, as in Drawing 'C'. The top round section must be slightly smaller in width than the rectangular tube, so it will rest on the bevel, rather than just sitting on top of the tube. This is to make sure that a narrow channel exists on either side of the upper round section, as shown in Drawing 'G'. If necessary, place the round section in a vice and gently tighten the jaws until the tube is squashed slightly and will fit the bevel as required. Tighten the hose clips just enough to hold the two halves together, *but no more than that*. The inside height of this assembly must now be measured with a vernier gauge, if available, though a length of wire cut to the correct length can be used. As can be seen in Drawing 'G', the inside height should be 25.5 to 26mm. This measurement should exist along the entire length of the assembly. It will be necessary to do a small amount of adjustment to achieve this measurement.

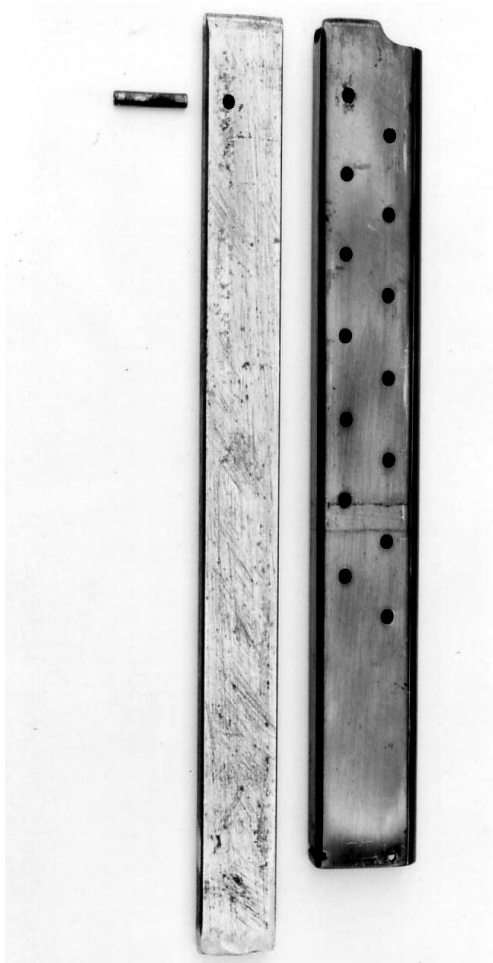

Photo 10: The magazine, form block and pin.

With any adjustments made and the two halves clamped together, apply flux to the entire length of both joints and silver solder the two sections together. Use a propane gas torch and heat several inches of the magazine along one side. Apply the solder and allow it to flow along the channel created by the bevel. Carry out this procedure at the other end of the magazine, then turn the magazine around and apply the solder to the opposite joint. Allow to cool and then remove any excess solder from the inside and outside of the magazine. Polish the outside walls with sandpaper, paying particular attention to

the joint areas. The body of the magazine is now finished and we can begin to cut it to shape. So as to make this a simple procedure; the accompanying template, (See *Figure G*), should be glued to the magazine body so that the bottom straight end is level with the end of the magazine. Use a scribe and mark the small curved cut out shape onto the top of the magazine. Punch the positions of the 14 cartridge viewing holes (optional) and then remove the template. The 14 holes are 3mm in diameter and are drilled through the magazine body from one side to the other. The top curved cut out section is shaped, using a half round file.

A recess and slot are now cut into the back wall of the magazine. The top recess is 6mm deep and as wide as the magazine side walls will allow. The lower slot is cut using a hacksaw blade and is positioned about 2mm above the bottom edge of the magazine. This slot should be around 1.5mm deep and again, as wide as the side walls will permit. The base plate retaining spring will fit into this slot in due course.

A considerable amount of burring will exist inside the magazine due to the filing and drilling. This should be completely removed with a flat file so that the inside walls are completely smooth.

All the necessary recesses and holes have now been made and we can proceed to form the magazine 'lips'. The magazine lips are responsible for holding the stack of

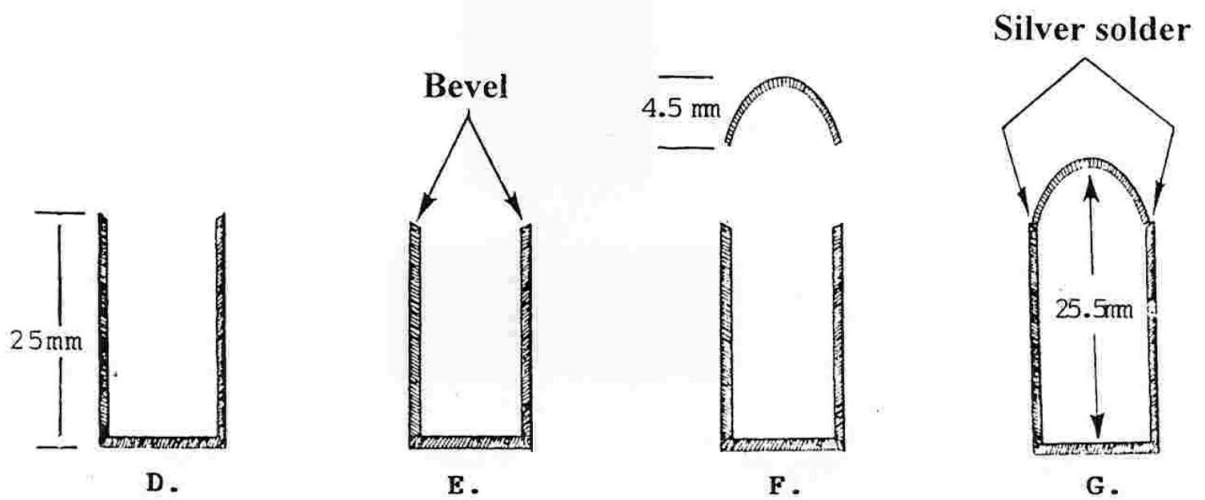
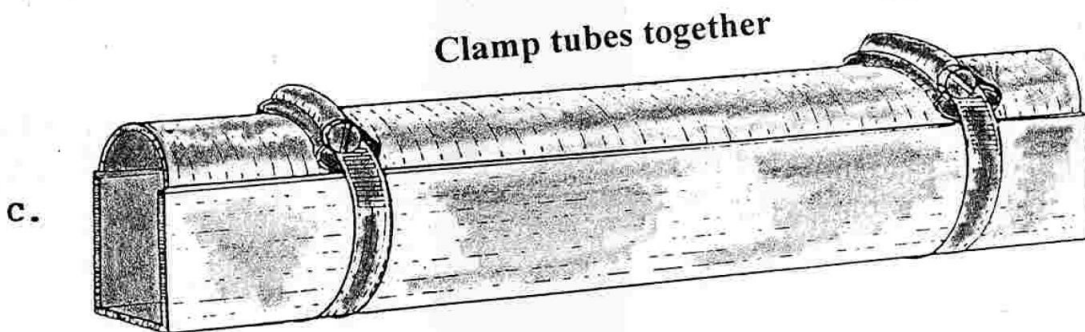
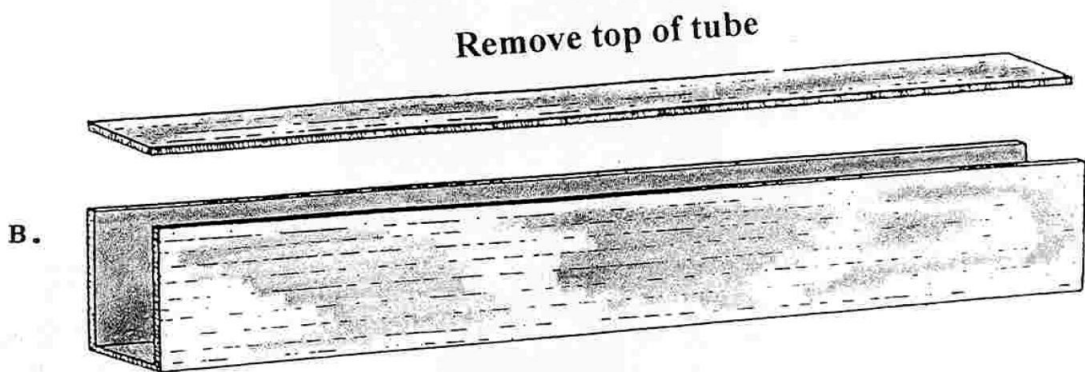
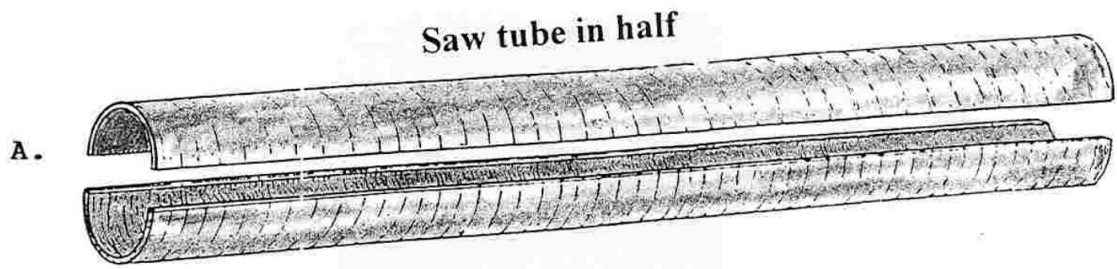

FIGURE 'F'. MAGAZINE CONSTRUCTION

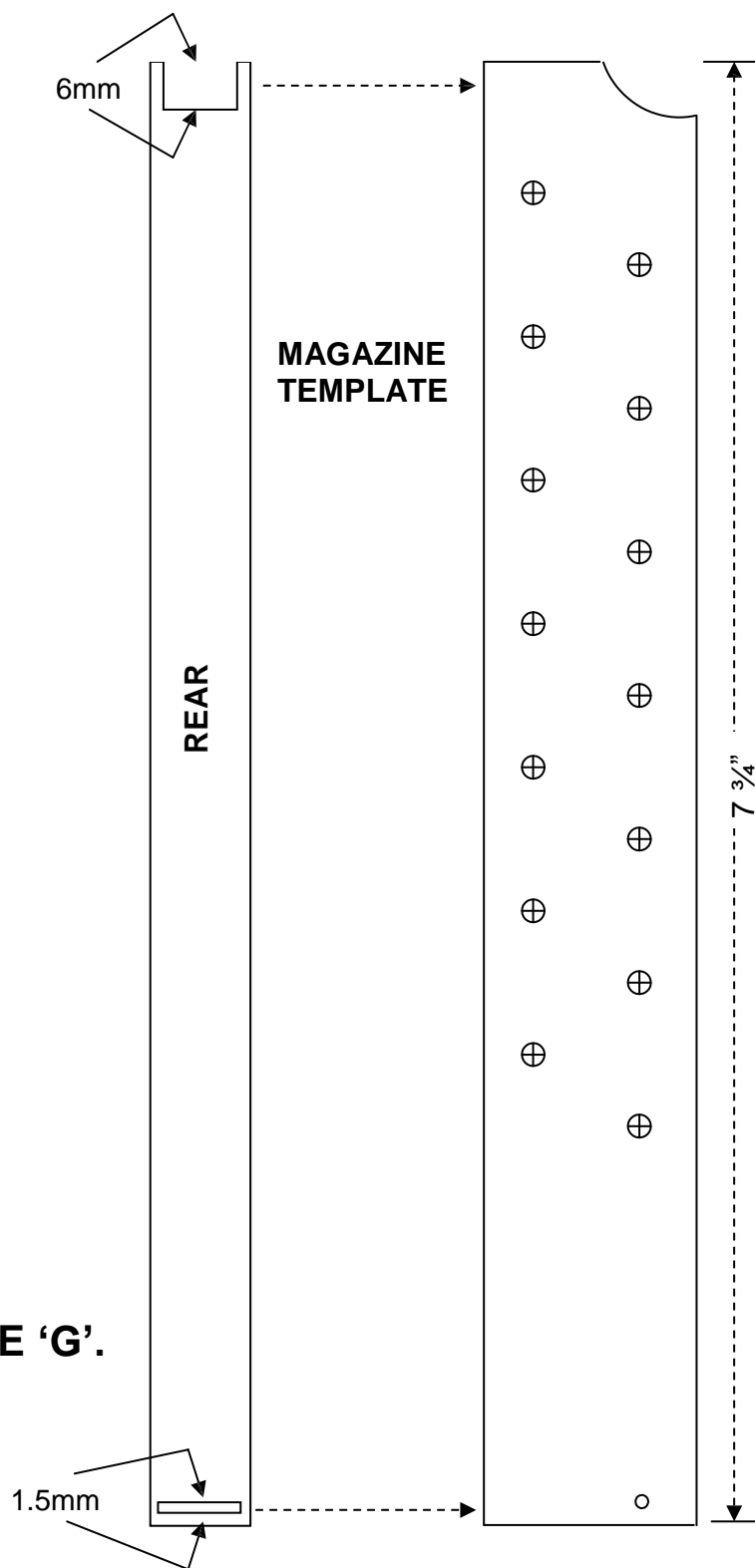

FIGURE 'G'.

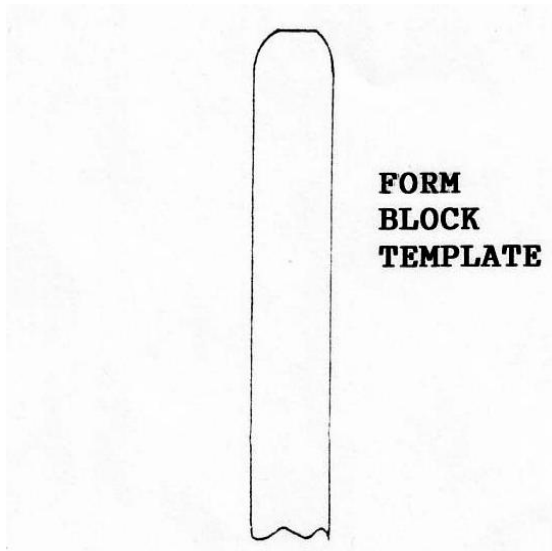

FIGURE H.

The form block must be filed to the shape of the above drawing



Photo 11: rear view of magazine with form block pinned in place

cartridges inside the magazine and must be formed to the correct contour to ensure smooth feeding of cartridges from magazine to chamber. For this reason, a simple 'form block' must be made, around which the lips are formed.

The block is an 8" length of 9.5 x 19.05mm ($\frac{3}{8}$ " x $\frac{3}{4}$ ") flat bar. One end of the block

must be shaped to the correct contour as shown in the accompanying template, (See Figure H). There is no need to copy or cut out the template, it should be used as a guide over which the block is laid. Secure a large file, flat side facing up, in a vice. Hold the form block bar away from you against the file. Draw the bar towards you while at the same time lifting it, maintaining a constant firm pressure. This method will shape the end of the block correctly, and is a foolproof procedure. Turn the block over and do the same to the other side. At intervals during filing, check the block against the drawing and make sure it is as close as possible to the template contour. Slide the block inside the magazine and position it so the curved end is about 1mm below the top of the lips. Drill through the top most viewing hole and all the way through the block, using the same diameter drill as used for the holes. Tap in a spring pin $\frac{3}{4}$ " in length to securely hold the form block inside the magazine body, (Photo 11).

Clamp this assembly in a vice so the jaws are holding it firmly just under the spring pin position. Place a short length of rod, about 6mm in diameter, against the top of the lips and firmly tap it with a hammer. Move the rod back and forth along the length of each lip until they are formed to the contours of the block. Now measure the distance between the lips, it should be 7.5mm, (See Appendix 'E' for .380 dimensions). If the gap is less than this slide the block back inside the magazine and gently tap the bottom of the block

effectively driving it upwards, and thus increasing the distance between the lips. Polish the inside top edges of each lip with a small piece of sandpaper to remove any sharp edges.

We are now ready to make and fit the internal parts of the magazine. These consist of the 'follower', 'mainspring', 'base plate' and 'retaining spring'. The follower is made and fitted first. This is nothing more than a piece of 9.5mm ($3/8''$) x 16 gauge steel strip, cut to a length of 59 mm. Measure in a distance of 35mm from one end and score a straight line. Clamp the strip in a vice so the top of the jaws are level with the score line. Using a hammer, bend the follower to the contour of Figure 'I'. Round the front tip of the follower before bending, and also, file a taper onto the followers lower leg in the position shown.

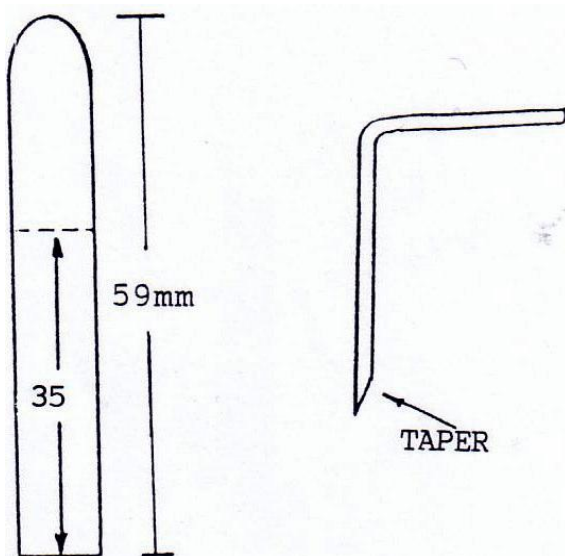

FIGURE I.

A small amount of filing to the sides and front round tip of the follower may be necessary before it will slide inside the magazine. Either way, it should be a loose sliding fit, so it will run perfectly smoothly back and forth inside the magazine tube.

SPRING MANDREL



Photo 12: Spring mandrel.

Now we can coil the mainspring, but before we can do this, a simple mandrel must be made around which to coil it. For this, three steel rods are required, 6mm in diameter and $14''$ in length. Each rod should be washed so it is thoroughly clean, then clamped in a vice, each on top of the other with the rod ends level. Using a gas torch, heat the end of the rods and braze them together for a length of about an inch, (*Photo 12*). Carry out this same procedure to the opposite end of the assembly and then allow it to cool. Drill a small 1.0 to 1.5mm hole through the rod assembly close to one end, through which to feed the spring steel wire. We require 20 gauge wire from which to make the spring. Music or piano wire, as it is commonly called, is usually sold in rolls of 25 foot lengths, and is widely available from most good model engineering shops and spring manufacturers. Do not use any wire

other than 20 gauge, or the spring will be too heavy or too light. A six foot length of wire is enough for coiling the spring. Insert the end of the wire through the mandrel hole and knot it to prevent the wire from pulling out. Stand on the wire and pull up on the mandrel until the wire is taut. Alternatively, tie the end of the wire to a stationary object such as a vice, door handle, etc. Hold the mandrel at an angle with both hands and start to turn it to coil the spring. With the spring coiled along the length of the mandrel a gap of around 10mm should exist between each coil of wire. When coiling the spring, the gap can be adjusted by simply increasing or decreasing the angle at which the mandrel is held, (*See Figure J*). Releasing tension on the wire will allow the spring to partially unwind, the spring becoming triangular in shape. Snip through the knot of wire and slide the spring from the mandrel. The spring must now be bent back into its original rectangular shape. Use your fingers only for this operation and squeeze the sides of each coil back into their correct shape. This is an obvious and straightforward procedure and it will become self-explanatory about how to do this on seeing the spring, though difficult to explain in words. When we coil any spring, whether round or rectangular, it will always uncoil when tension is released. The round spring will still remain round, but the rectangular version, unfortunately, will always need bending back to shape. Don't worry if the spring has a significant

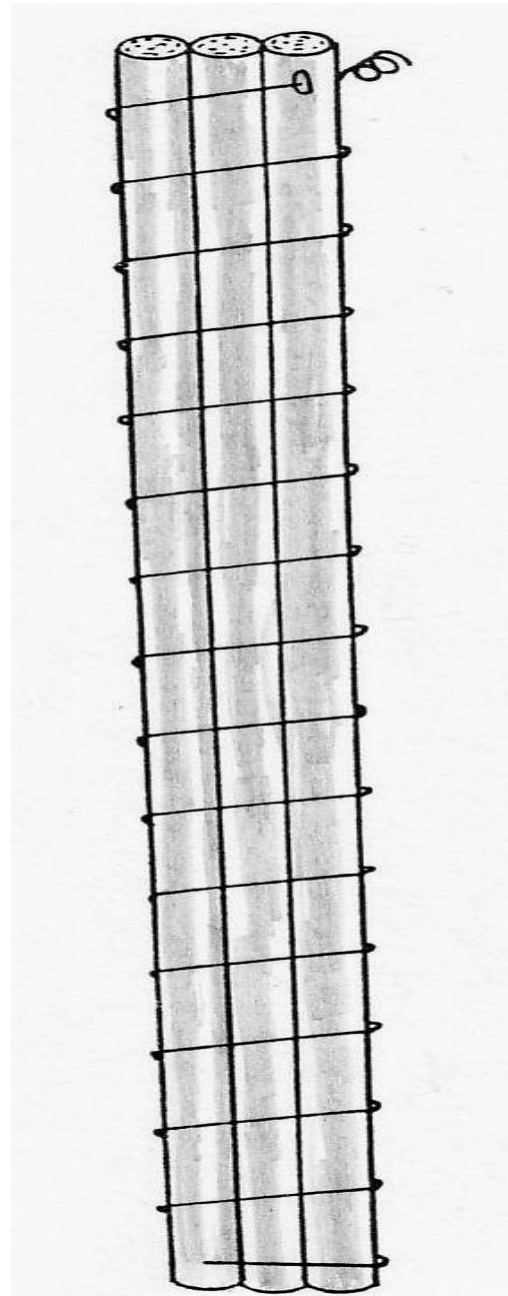

FIGURE J.

bend along its length when finished, as this will not interfere with the correct functioning of the magazine. The spring must now be compressed several times before it is trimmed to the correct length. The easiest way to do this is to slide a couple of 6mm diameter rods, the same length as the mandrel, through the spring.

Magazine Construction

These act as a guide and make compressing the spring a lot easier. The magazine spring will shrink in length from 14" to about 10". Now use a pair of pliers and cut the spring to a length of 8". The mainspring is now finished and ready to slide inside the magazine. Before the spring is inserted, one end must be fitted with the base plate to seal off the bottom of the magazine. The base plate is made from the same 9.5mm 16 gauge steel strip as used to make the follower. Cut a 25mm length of the steel and round off one end so it is a good fit inside the bottom of the magazine. Drill a 4mm diameter hole through the middle of the plate so it can be bolted to the spring. Bend the last coil of the spring into a loop and use a 4mm diameter socket screw, nut and washer, to bolt the base plate to the spring, (See Figure K).

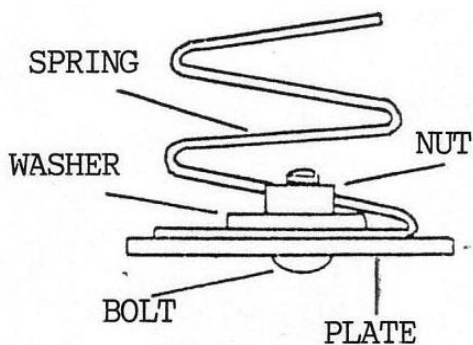

FIGURE K.

The base plate retaining spring can now be made. A length of the 20 gauge spring wire, 60mm long, is required from which to form the spring. A length of steel rod 6mm in diameter and about 6" in length is also required around which to form the spring.

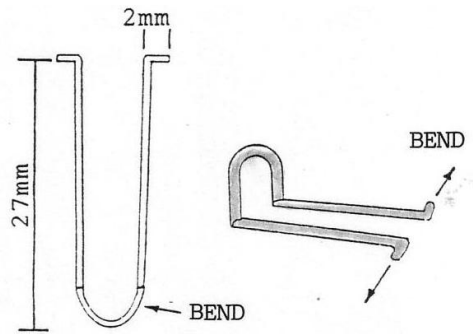

FIGURE L.

Clamp the rod in a vice in a vertical position so that 4" to 5" of the rod is visible above the vice jaws. Position the middle section of the wire against the rod and bend the wire into a 'U' shape, (See Figure L). Clamp the open end of this spring in a vice so the curved end is visible above the jaws. Tap this protruding section with a hammer until it is bent flat across the top of the jaws. The tip of each of the two spring 'forks' must now be bent outwards for a length of 2mm. It is best to clamp the tips of each fork in a vice and bend them to shape using a hammer and punch. If the two bent sections are longer than the 2 mm required, they should be reduced using a grinder.

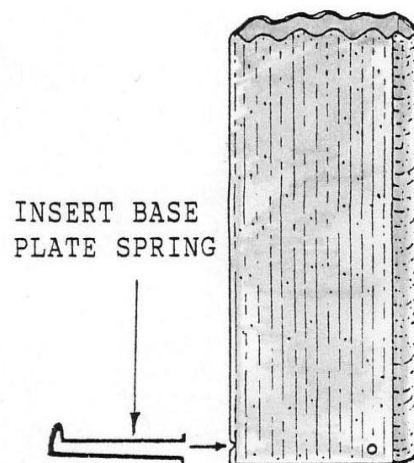

FIGURE M.

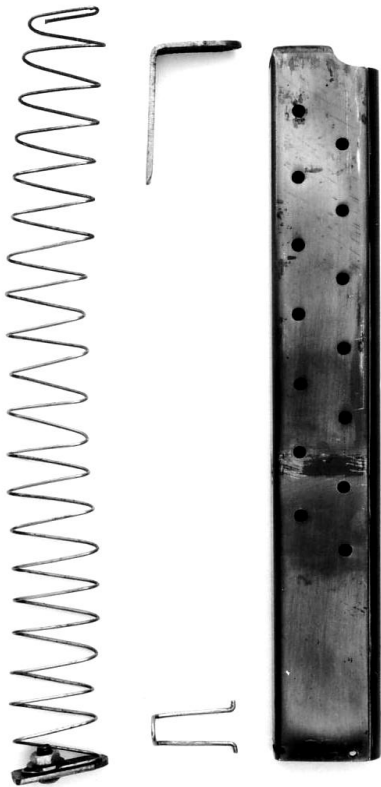

Photo 13: The magazine ready for assembly.

The spring must now be inserted into the slot in the bottom rear wall of the magazine, so we can mark the position at which to drill the hole that will hold the spring in position, (See Figure M). With the spring fully inserted, mark the bottom edge of the magazine, at the position where the two forks are pointing. Transfer this position to the side of the magazine about 2mm up from the magazines lower edge. Now drill a hole at this point 1.0 to 1.5mm in diameter through the magazine from one side to the other. When the spring is now re-inserted, the two forks should *snap* into the holes, and prevent the spring from falling out. Remove the spring and the internal parts can be inserted, (Photo 13). Slide the follower into the magazine first,

followed by the mainspring and base plate assembly, and then refit the retaining spring, to hold all the parts in place.

MAGAZINE STOP

The magazine is now fully assembled except for the 'stop'. This is nothing more elaborate than a thin slice of the 15.88 x 34.93mm x 16 gauge tube, used to make the magazine well. The stop prevents the magazine from being pushed too far into the weapon, and also, holds the magazine in position by hooking onto the spring catch. One end of the stop is filed to a taper and the other end is removed completely, (See Figure N).

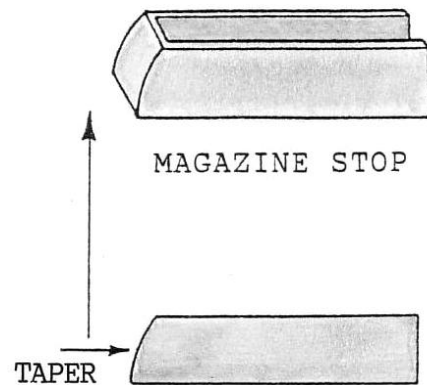

FIGURE N.

Before the stop is cut from the tubing, the gap between the *bottom of the well and the top edge of the spring catch* must be measured. It should be about 6mm, but it may be slightly more or less, depending on how the catch loop was formed. Assuming the gap is 6mm, a 6mm thick section of the 15.88 x 34.93mm tube should be cut out. Remove one end of the stop using a hacksaw and round off the ends of the two resulting prongs with a file.

Magazine Construction



Photo14: The assembled magazine.



Photo 15: The spring catch holding magazine in place.

A taper is then filed on the opposite end and polished smooth. The taper allows the catch to slide over the stop, effectively holding the magazine in position. The stops top and bottom sides should be filed completely flat by sliding it back and forth across the surface of a file. This is important because the stop must mate perfectly with the bottom edge of the well when the magazine is inserted into the weapon. Slide the stop over the magazine between the 11th and 12th viewing holes, (*Photo 14*). This is only a rough setting; the stop must remain loose until the entire weapon is built, when it will be soldered permanently in place.

Insert the magazine into the well and the catch should slide over the stop and snap into position, holding the magazine firmly in position, (*Photo 15*). A small amount of filing may be required before the catch will snap into place, and very little free play should exist between the catch and stop. The magazine, when inserted, should be under constant forward pressure from the top of the spring catch and the catch loop itself. The spring eliminates the excess space in the rear of the well, effectively holding the magazine as close to the feed ramp as possible.

4

THE TRIGGER

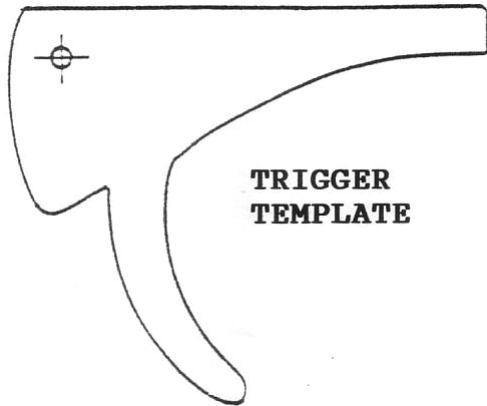

FIGURE O.

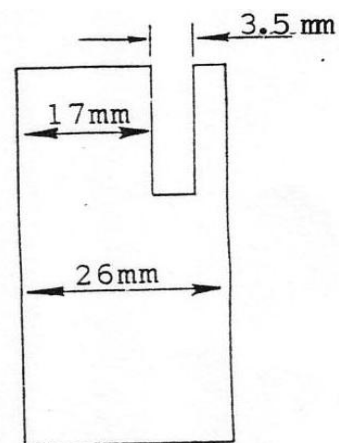

Photo 16: The trigger is cut from a section of steel plate.

We can now fit the trigger and guard. Both are very simple and straightforward parts to make. We will start with the trigger by cutting out the accompanying template and gluing it to a section of $\frac{1}{8}$ " thick steel plate, (See Figure O). The plate should measure a minimum of 3" x 2". Mark around the template and punch mark the crossed circle. Cut out the trigger with a hacksaw and file to shape. The section of the trigger that is pulled by the

finger should be sanded smooth, so it is comfortable when pulled. Drill a 4mm diameter hole through the trigger in the punch marked position, as shown in (Photo 16). Insert the trigger into the receiver through the guard recess and secure it in position with a 4mm socket screw and nut. The trigger should pivot smoothly on the screw without any snagging or binding.

The trigger guard is constructed from a section of 50.80mm (2") diameter, 16 gauge tubing. The tube should be 26mm in length and each end should be filed perfectly flat by sliding the guard back and forth over a flat file. Now secure the guard in a vice, but to prevent the jaws from squashing it, tighten the jaws against the *ends* of the guard, rather than the sides. Use a hacksaw and remove a section of the guard so as to create a slot to the measurements in Drawing 'A'. This slot allows the trigger to pass through the trigger guard. Looking at the guard as a clock face, the slot is cut so the cutting edge of the hacksaw blade is pointing to the 'ten to two' position, as in Drawing 'B'.



A.

Trigger And Guard

The guard should be a tight push fit in the guard recess, so it will stay in position of its own accord without any soldering; though it is best to solder it in place so it is secure. It will probably be necessary to squeeze the sides of the guard, so as to make it a slight oval shape, before it is possible to press the guard into place, (*Photo 17*). With the guard fitted, make sure it does not prevent the trigger from moving freely. If it does, increase the width of the slot.

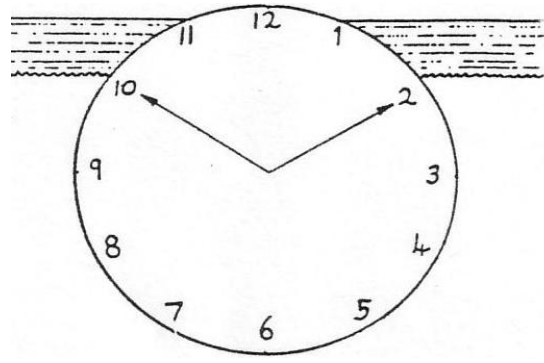

DRAWING B.

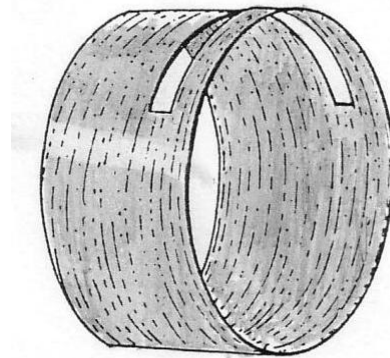

Photo 17: Trigger and guard fitted to receiver

5

THE SEAR

The sear is the section of the trigger mechanism that releases the breech block when the trigger is pulled. It is made by modifying a 10mm diameter hexagonal wrench, also referred to as Hexagonal 'Keys'. These are widely available from most good hardware stores. They are made from hardened steel, and because of their shape, lend themselves ideally to the construction of an expedient sear. Keys can vary in length depending on the manufacturer, but length does not matter in this case as we only require the keys middle section. This does, however, make giving any measurements for the necessary modifications difficult. For this reason I have supplied four templates to make shaping the key a simple operation, (*See Figure Q*). Both ends of the key must be removed until it is the same length as Drawing 'A'. It is not possible to saw through the key with a hacksaw due to the hardness of the steel, so an angle grinder, preferably fitted with a slitting wheel, must be used. If an angle grinder is absolutely unavailable, one of the tungsten coated hacksaw blades can be used, though they are quite expensive. The top curved section of the key is

shaped using a file and then polished smooth with sandpaper. The templates are not copied and removed, but rather, the key is laid over them at intervals until the key matches the templates. The side of the key, which we will now refer to as the sear, is filed flat in the position illustrated in Drawing 'B'. It is quicker to use a bench grinder to remove the bulk of the steel before finishing off using a file. Only file away enough steel until the corner edge is completely flat, and no further. This flat area allows the front section of the trigger to rest positively against the side of the sear. As shown in drawing 'C', three holes are now drilled through the sear to the diameters and positions shown. The larger of these holes is drilled first. This is the sear pivot bolt hole, it is 5mm in diameter and positioned 13mm from the end of the sear. The hole can be drilled in the sears present hardened condition or it can be annealed. This will depend on what type of drill bits are used. It is preferable to drill the holes without annealing the steel by using 'Cobalt' drill bits. These are specially designed for drilling through hard steel and are very useful, though quite expensive. If these are unavailable, the sear should be heated until it is glowing bright red in colour at the areas where the holes are to be made. This should be done twice, allowing the steel to cool *slowly* between each heating. It is best to use a propane gas torch for this procedure as it gives far higher temperatures than a torch fitted with a butane cartridge. Because the sear is octagonal in shape, the first hole has to be drilled on a corner edge.

Sear Construction

First, drill a 2mm diameter hole through the sear, 13mm from the end, then re-drill the hole to its final 5mm diameter. The second 2.5mm hole is now drilled to the right of the 5mm hole. The exact position of it is not too important, but roughly speaking, it is about 3mm from the end of the sear. Again, file a flat area before attempting to drill the hole, so the drill does not slide off the corner. Another 2.5mm hole is now drilled through the flattened area, 44mm from the end of the sear. The hole is situated just below the corner edge, as shown in Drawing 'C'. The finished sear is shown in Drawing 'D'.

Finally, tap a 2.5mm diameter spring pin into each 2.5mm hole until an even length of pin is visible at either side of the sear, (Photos 18 and 19). Each pin should be 1" in length. The sear is now ready to be fitted, but before this can be done, we must make the sear spring, (Photo 20). This is made from a length of ½" x 20 gauge spring steel strip. The spring should be 88mm in length. Drill a 6mm diameter hole a distance of 9mm from one end of the spring, then bend it, using your fingers, to roughly the same shape as Figure 'R'.

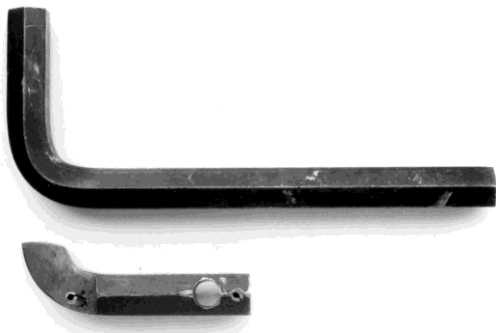

Photo 18: The sear is a modified key.

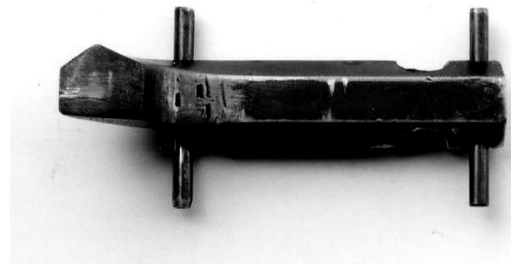

Photo 19: Top view of sear with both pins fitted.



Photo 20: Sear spring, screw and nut.

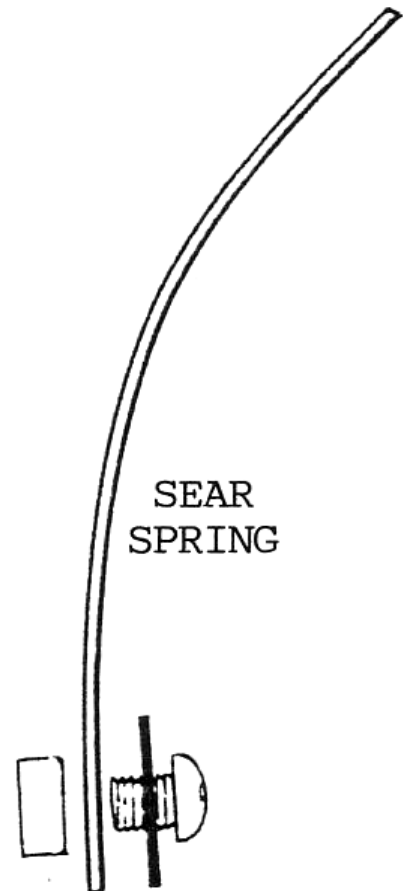
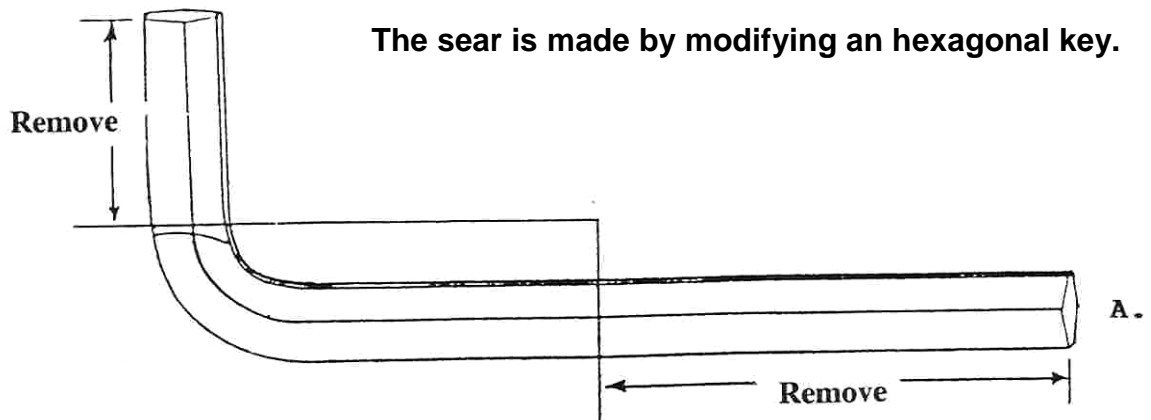
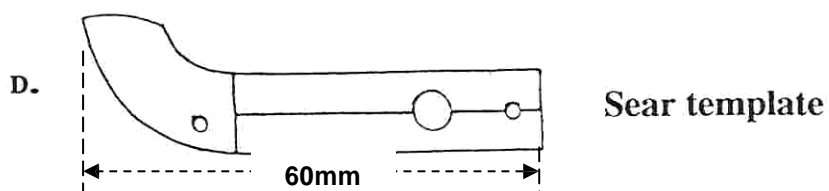
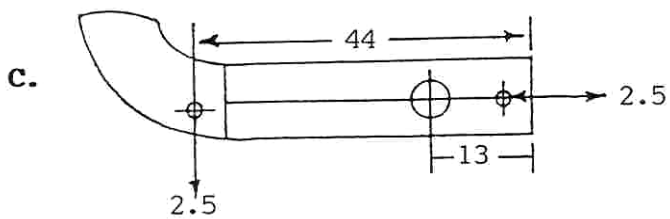
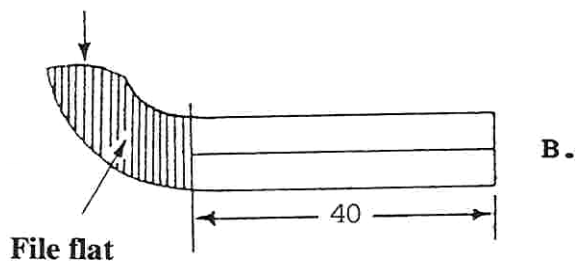

FIGURE R.

FIGURE 'Q' SEAR CONSTRUCTION



File to shape



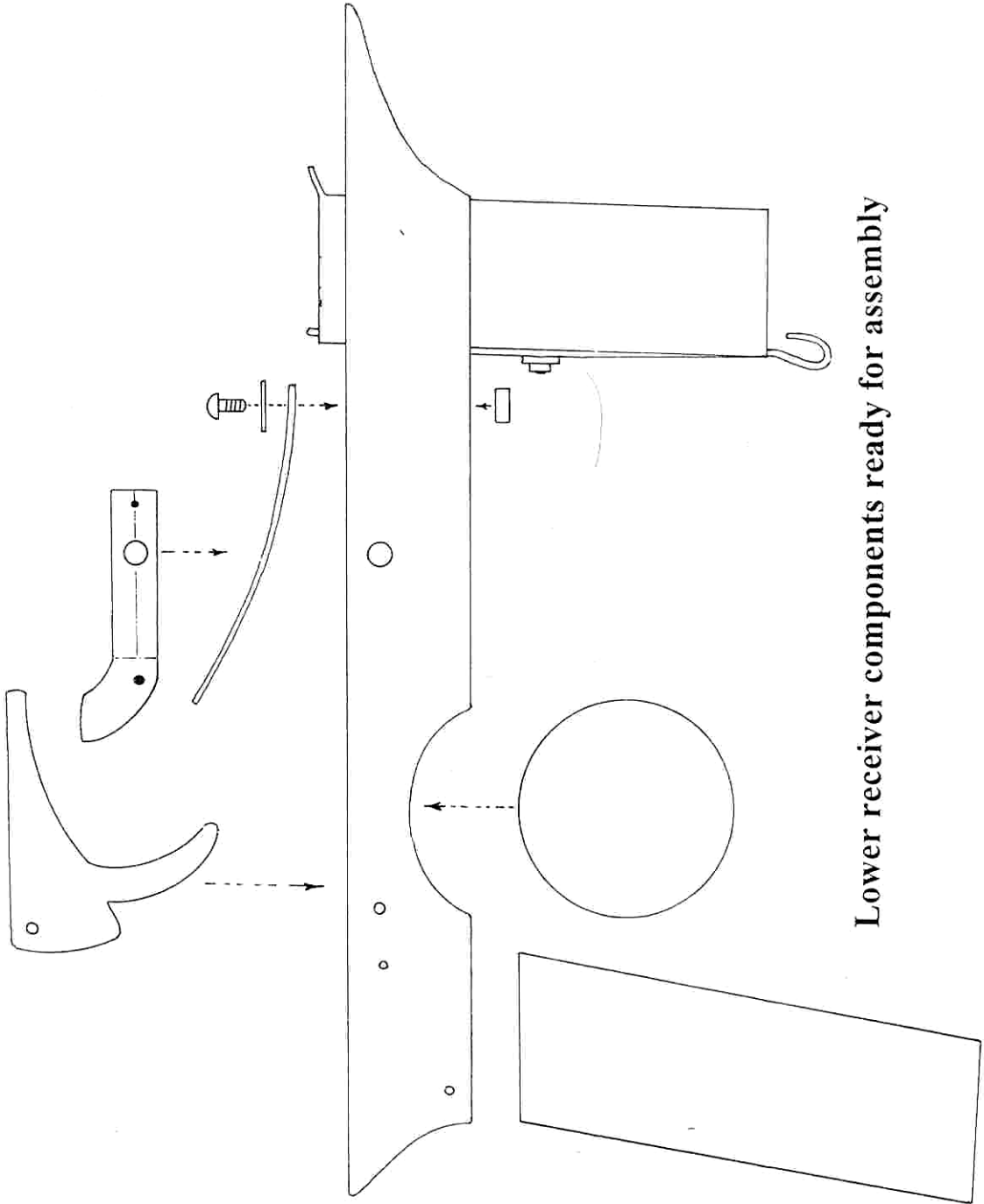

Lower receiver components ready for assembly

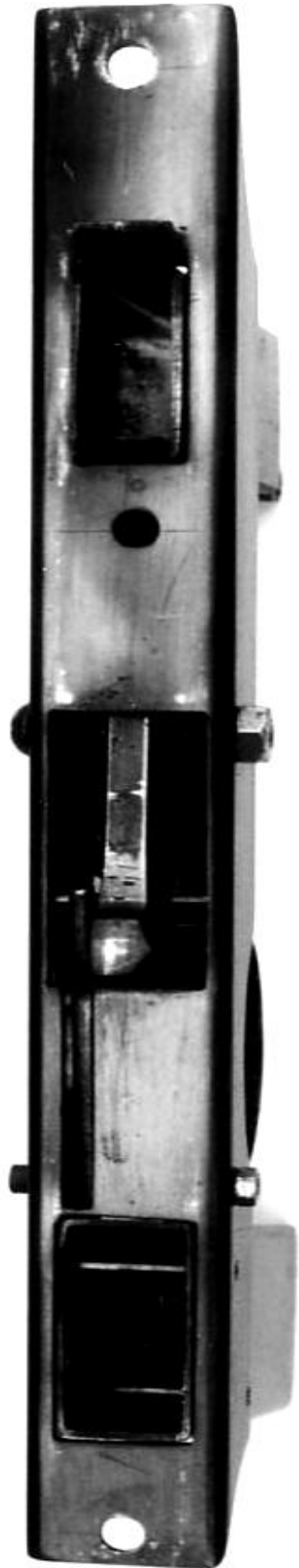

Insert the spring through the sear recess and secure it in place with a socket screw washer and nut. The sear is now positioned over the spring and secured in place with a 5mm diameter socket screw. This should be 35mm in length and held in place with a nut. The long front section of the trigger leg should be resting on top of the protruding pin on the flat side of the sear. When the trigger is pulled, the sear should drop down so its top curved end is level with the top of the receiver, (Photo 21).

Don't worry if it is slightly above or below this position, it will still release the breech block perfectly well. The main priority is that the sear does not bind or snag on the sear recess or the trigger. It should move smoothly and be under constant upwards pressure from the spring.

The lower receiver is now fully assembled, (See Photo 22), and we can start to build the upper half of the machine pistol.

Photo 21: Top view of assembled receiver.

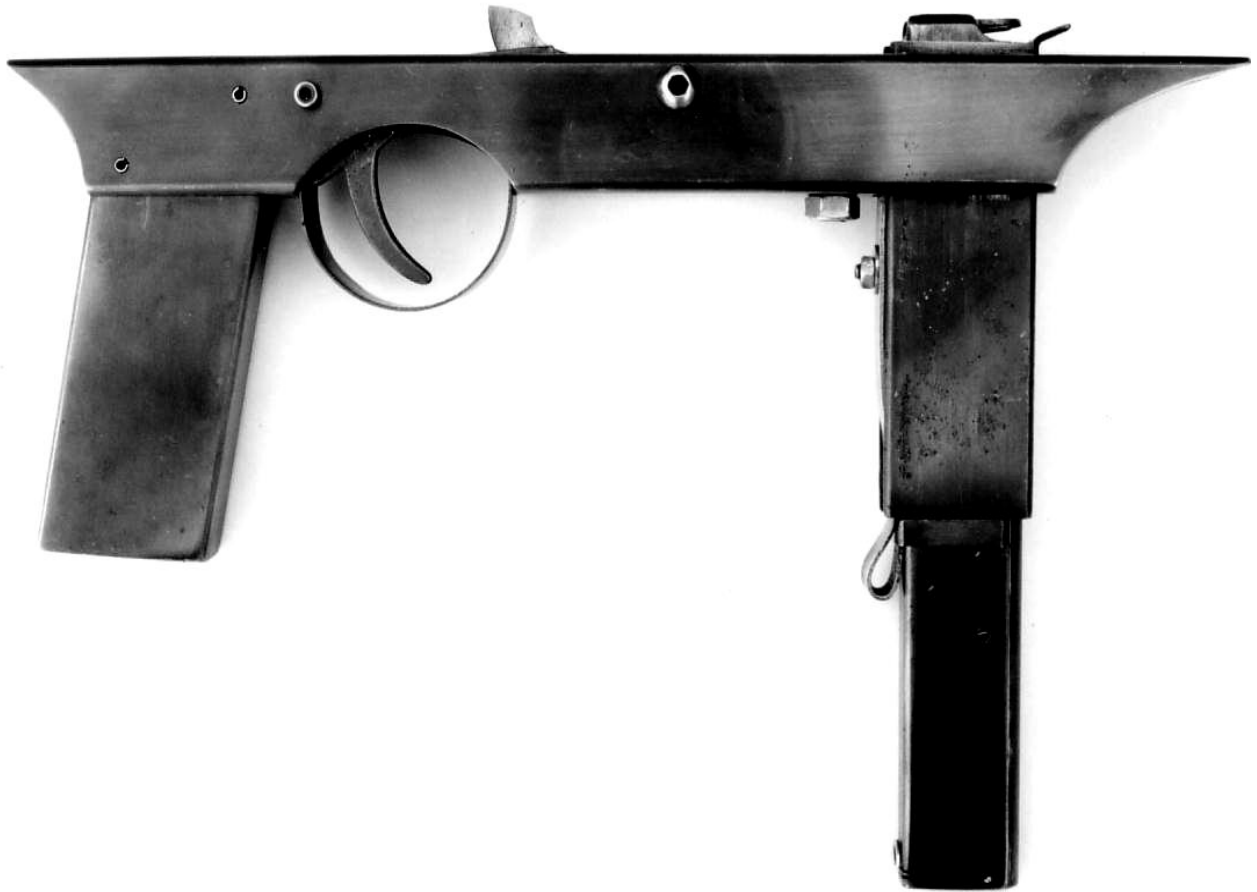

Photo 22: The fully assembled lower receiver.

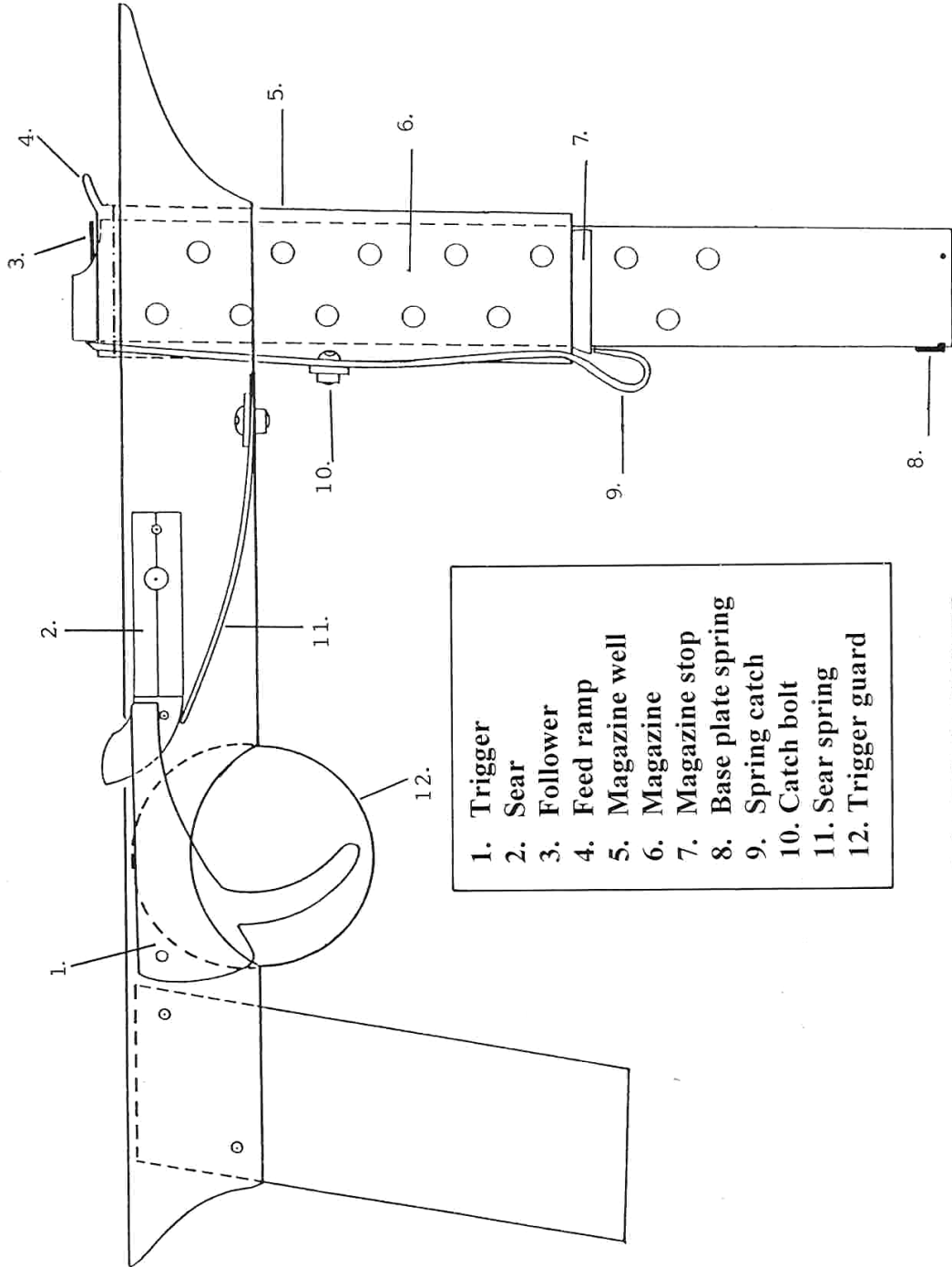

FIGURE 'S' FULLY ASSEMBLED LOWER RECEIVER.

6

UPPER RECEIVER

The upper receiver is constructed from an 11 ½” length of 30 x 30 x 2mm box section tubing. This is exactly the same size used for the lower receiver, except that the gauge must be heavier, namely, a wall thickness of 2mm. Before we can cut the necessary recesses into the tube, it must be temporarily attached to the top of the lower receiver using a couple of hose clips, (*Photo 23*). To do this, the magazine well and grip must be removed. Make sure that the breech, (grip end) of both tubes are level, and that each tube is in as near perfect alignment as possible. Thoroughly tighten both clips to keep the tubes in this position. Clamp this assembly in a vice, (lower receiver facing up) and drill a 6mm hole through the two lower receiver bolt holes and through into the upper receiver, (*Photo 24*). By drilling through the two receivers in this way, we can be sure that they will be in accurate alignment when the weapon is finally assembled.

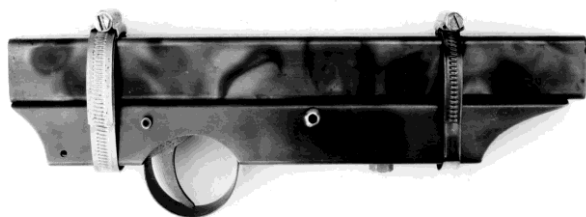

Photo 23: The receivers are clamped together with two hose clips.



Photo 24: Drilling through the lower receiver bolt holes.

With both receivers still clamped together, scribe the letters “EP” onto the right side of the upper receiver. On the opposite (left side) scribe the letters “EH” and then remove the hose clips, (*See Figure T*). Where the two receivers were joined together, (bottom side), scribe “MW”. It is necessary to mark each side of the receiver in this way to ensure the following recesses are cut into the *correct sides* of the receiver. These letter reference marks stand for *Ejection Port* (EP), *Ejector Hole* (EH), and *Magazine Well* (MW). The lower receiver can now be re-assembled and put to one side as we will not require it again until the upper receiver is fully assembled. The recesses can now be cut into the upper receiver, (*See Figure U*).

We will start with Drawing ‘A’, which shows the positions of the ejection port and the bolt handle slot. Use a set square and scribe the position of the ejection port onto the right side of the receiver, where we marked “EP” earlier. The port cannot be cut out with a hacksaw, so a series of inter-connecting holes, 3 or 4mm diameter, are drilled along the inside of the score line marks. This will allow

Upper Receiver

the unwanted section of steel to be removed using a short length of rod and a hammer. The jagged edges around the inside circumference of the port can now be filed smooth.

The bolt handle slot is now cut into the top right hand corner of the receiver. It is positioned 55mm from the breech end of the receiver and is 110mm in length. Mark the beginning and end of the slot, then file a flat area between the two marks. This flat area should be just wide enough to allow the corner edge to be drilled without the drill slipping off the corner. Again, this recess cannot be cut out with a saw, so drill a series of holes, 6mm in diameter, along the entire length of the flat area. An angle grinder is now used to cut through and widen the slot. This will allow a flat file to enter the slot, which is then used to file it to a width of 6 to 6.5 mm, (*Photo 25*).

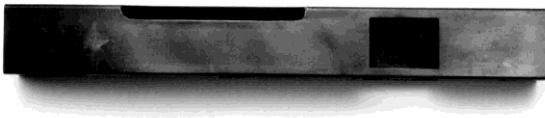

Photo 25: The upper receiver with all recesses cut.

The slot can be cut in a lower position if required, *but no lower* than 20mm from the lower edge of the receiver. This lower position of the bolt handle slot is the more aesthetically pleasing one, if looks are of

importance to you, but I have simply placed the slot in the exact corner position, as a 'Happy Medium' so to speak. It is really just down to personal preference as to where the slot is positioned.

We can now turn to Drawing 'B' and cut the recesses for the magazine well and sear. Use a set square again to keep each scribe mark as square and accurate as possible, then cut out in the position shown using the same methods described above. Five holes are now drilled through the left side of the receiver, as shown in Drawing 'C'. Scribe a line down the length of the left side, as near to the centre as possible. Make a punch mark 76mm along this line (from the front of the receiver) and drill a 6.5mm diameter hole at this position. This hole will later accept the ejector bolt

All recesses have now been cut except for the four holes along the bottom of Drawing 'C'. These holes are 3mm in diameter and will shortly accept the sling loops. However, until the loops are made, only drill two of the holes, to the measurements in Figure 'U', Drawing 'C'. The sling loops are formed from a length of 3mm diameter (or slightly larger) steel rod, as shown in Figure 'V'. Cut off two 65mm lengths of rod and file a point onto each end. Ordinary mild steel rod is perfectly strong enough for the sling loops. Measure in 20mm from each end of the rod and form them into a 'U' shape by bending them at this point. The inside measurement of the sling loops should be

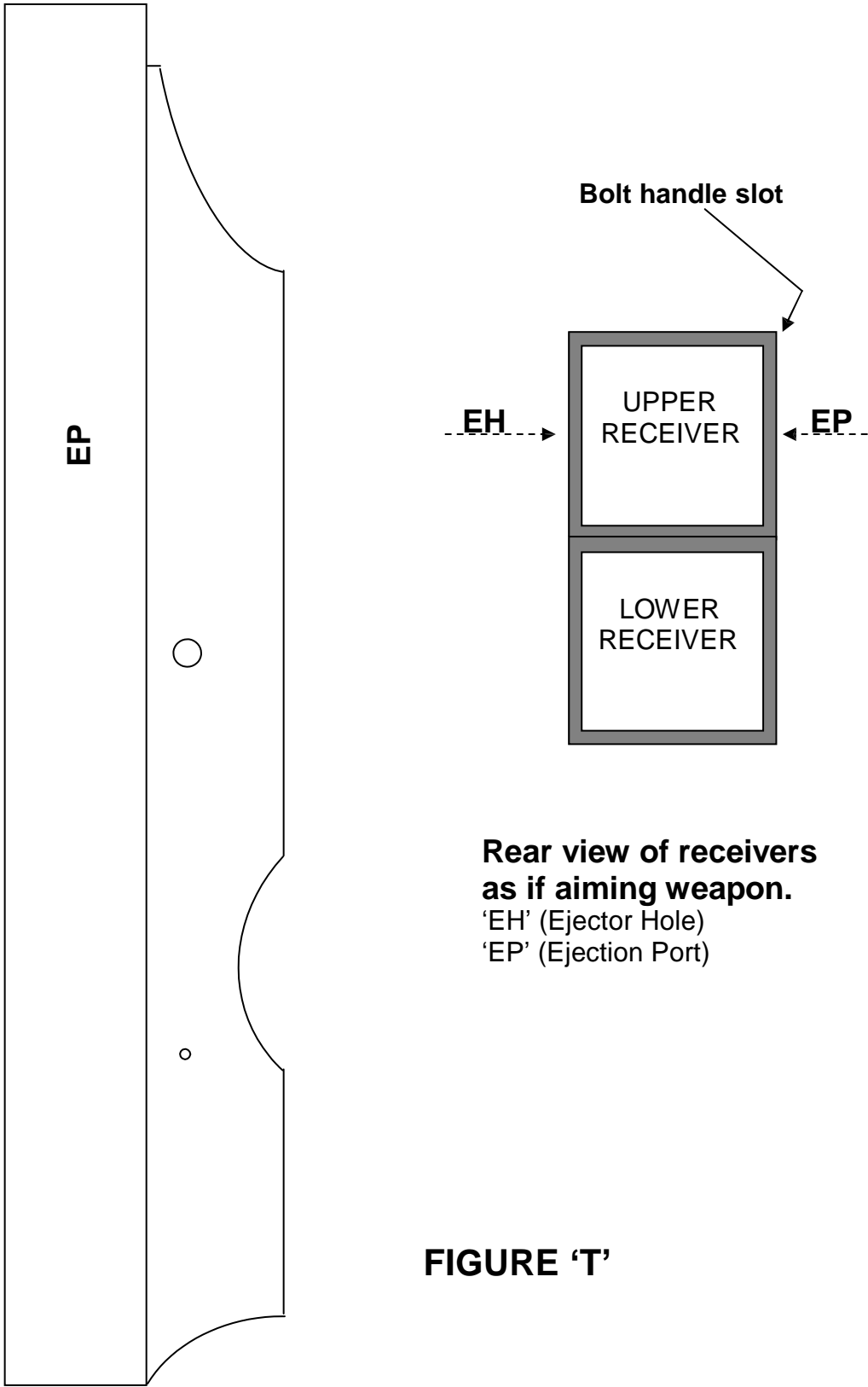

FIGURE 'T'

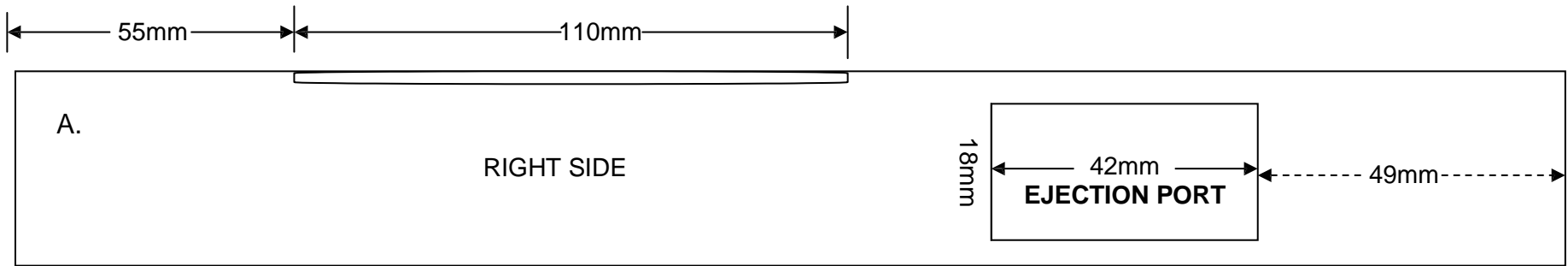
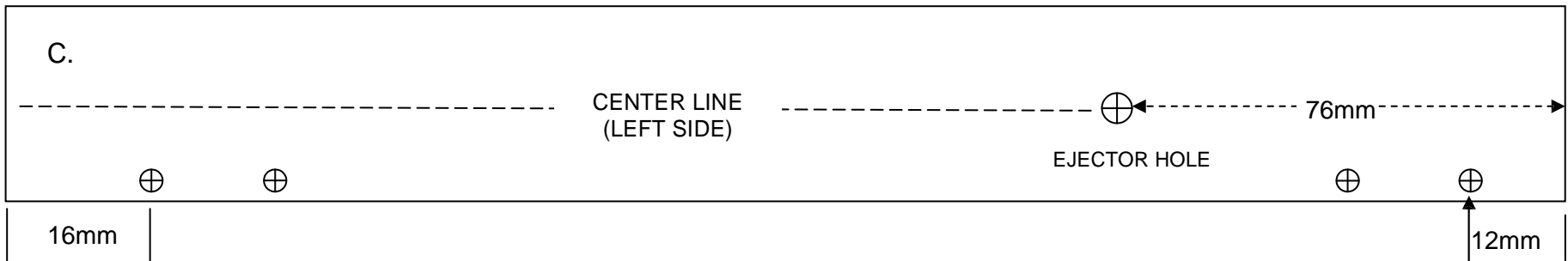
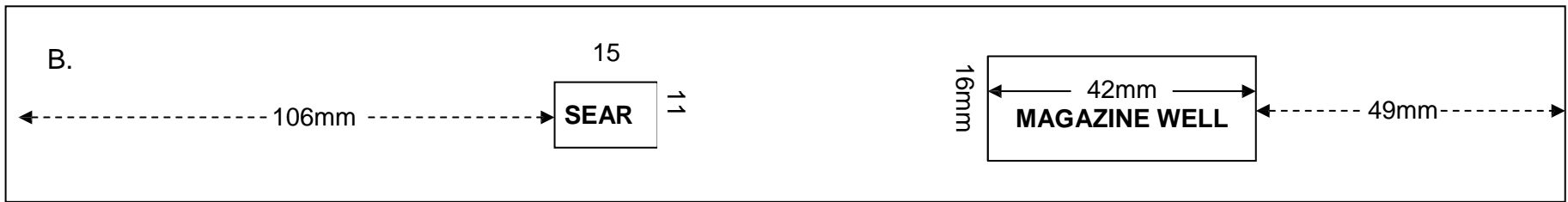

FIGURE U; UPPER RECEIVER RECESS POSITIONS



Upper Receiver

about 28mm, but don't worry if it slightly more or less, it does not matter too much. Insert one of the pointed legs into one of the loop holes and tap the other leg with a hammer. This will mark the position of the second loop hole position onto the side of the receiver. Now carry out this same procedure for the second loop and then drill the two holes.

Sling Loop

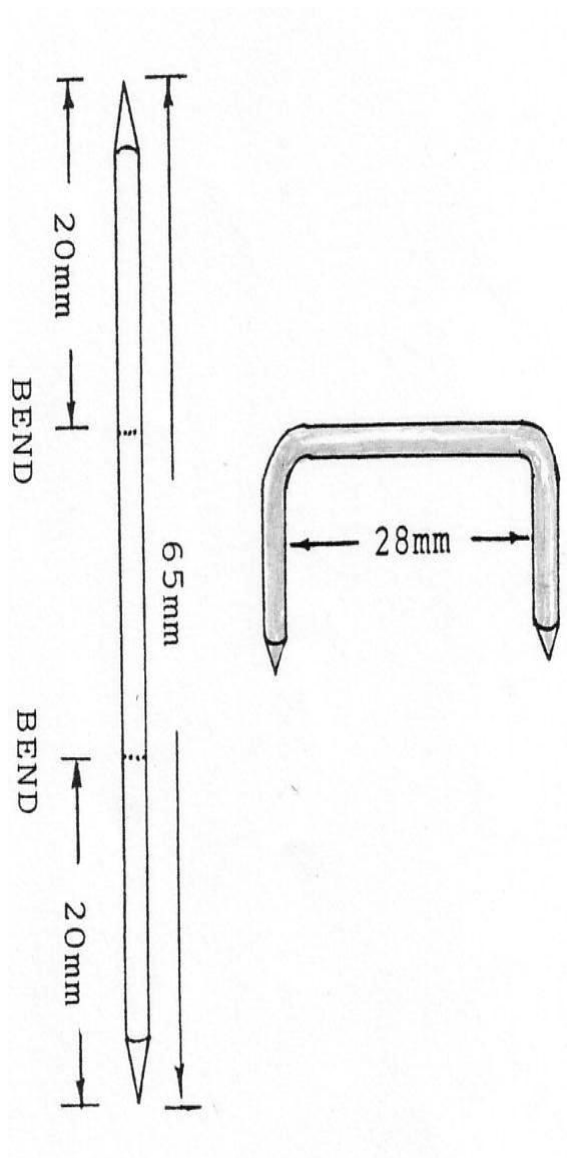

FIGURE V.



Photo 26: The Sling Loops are silver soldered in place.

Push each loop into position so they are protruding about 6mm ($\frac{1}{4}$ ") from the side of the receiver. Each sling loop is now permanently held in position with a small drop of silver solder, or ordinary electrical (Soft) solder, applied at the point where the loop legs pass through the side of the receiver, (*Photo 26*).

The upper receiver tube is now finished and ready to be fitted with the internal working parts. However, before we can fit the barrel, breech block, mainspring and recoil shield, we must install three 'Shaft Lock Collars' inside the receiver. The collars have two purposes, first, they allow the two receivers to be bolted together and, act as retainers for the barrel, bolt and mainspring assembly. Collars have a variety of uses such as retaining gears and pulleys on machine tools and are widely available from bolt and nut suppliers and good hardware stores. A collar is measured by the size of bar or shaft it is to fit, in other words, if a collar is required to fit a 1" diameter bar, we ask for a 1" collar. Our machine pistol requires fifteen $\frac{1}{2}$ " collars.

The outside diameter (OD) of the ½” collar is usually 1”, however, when purchasing, the OD must be measured to make sure they are of the correct diameter. It is well worth pointing out here that you will occasionally encounter collars which, although being ½” ,are not 1” OD, but slightly larger or smaller. This is due to the fact that different manufacturer may make collars to slightly different specifications. Provided the collars are between 25.40mm - 26mm (1”) they will be a good sliding fit inside the receiver tube. Also, measure the length (thickness) of the collars; they should be around 11mm in length. Each collar will be fitted with a grub screw, which, when tightened, holds the collar on the bar or tube to which it is fitted. These screws are not required for the three collars we are fitting inside the receiver; these should be unscrewed and discarded. The inside diameter, (ID), must be increased on two of the three collars from their present 12.70mm (½”) to an ID of 14.2mm. The reasons for this will become apparent later.

A 14.2mm, (9/16”), taper pin reamer is required for this purpose. Both straight and tapered reamers are extensively used in engineering, and are widely available second hand. A good source for supply are second hand tool and machinery dealers, where whole boxes of reamers may be found. Many bankrupt stock items in unused condition may also be acquired at a fraction of the new price. Whatever you do, do not buy new



Photo 27: The Collars are reamed out using a reamer or similar tool.

reamers, they are prohibitively expensive, and, as pointed out above, it is unnecessary to do so. When buying any reamer second-hand, always check that the cutting edges are sharp and undamaged, if in doubt, ask someone who knows! Securely clamp a collar in a vice and place the reamer in a suitable ‘Tap Holder’, or a manual drill could be used, provided the chuck is large enough to accept the diameter of reamer.

To make sure the reamer passes through the collar accurately, keep the reamer as close to a right angle to the collar face as possible. Apply very light forward pressure to the reamer until it passes all the way through the centre of the collar, (Photo 27). Exactly the same procedure is carried out on the second of the three collars. The collars are now ready to insert inside the receiver. Eleven 6mm diameter dome head socket screws, 6mm long (measured from the underside of the head to the end of the thread), are required to retain the collars in position. The socket screws must have the same thread size, (pitch), as the grub screws, so the socket screws will screw into the collars. A tap must also be

Upper Receiver

acquired with the same thread size as the screws. The two 6mm holes we drilled earlier, (when the two receivers were clamped together) allows two of the collars to be bolted inside the receiver. Insert the first modified collar into the receiver, just in front of the ejection port, and line up the collars grub screw hole with the receiver bolt hole. Use a hexagon key and screw in one of the socket screws through the receiver wall and into the collar. Tighten the screw to firmly hold the collar in place. Now insert the second, (unmodified), collar into the breech of the receiver and secure it in position using the same procedure. The third, (modified) collar is inserted to the left of the ejection port. Drill a 6mm hole in this position 5.5 mm from the left side of the port, securing it in place with a socket screw. Make sure that all three screws are thoroughly tight to prevent the collars from moving. The two collars at the front and breech end of the receiver are now drilled on the other *three sides*, so each collar will accept three more screws. The third collar, to the left of the port, is only drilled on two sides, i.e. the top and left sides. We cannot drill blindly through the receiver walls and hope to locate the centre of each collar. We must, therefore, find the position of each collar before drilling the holes. The easiest way is to use a set square and scribe a line around all three sides of the receiver in line with the centre of each socket screw fitted earlier. Now measure to the centre of each line and punch a mark. This will give you the position of the collars on



Photo 28: Three collars fitted to the receiver.

each side of the receiver. Where the punch marks indicate, drill a 2 to 3mm diameter hole through the other sides of the three collars. Now using the correct diameter of drill for the tap size, i.e. 5mm, re-drill each hole to the correct diameter. Each hole is now tapped, and the other eight socket screws fitted and tightened, (Photo 28). Look through the receiver from end to end and check that the screws cannot be seen in the centre of the collars. If the ends of the screws are visible they must be shortened.

With the collars secured inside the receiver, we can proceed to assemble and fit the barrel, breech block and mainspring assembly.

7

BARREL ASSEMBLY

Manufacturing a rifled gun barrel would require a lathe and rifling machine, and obviously, relatively few people own such equipment. With any firearm that can truly be described as homemade, we must compromise the inherent accuracy of the rifled barrel, for the easily constructed smooth-bore version. While the accuracy of the handgun or rifle is very important, the firepower of the machine gun means accuracy is of secondary importance. Reliably getting as many bullets to the target as rapidly as possible is the main consideration. If you do own, or have access to a lathe, the obvious method of barrel construction would be to machine it as a solid unit. The bore would require machining to a diameter of 7.5mm, using a 'long series' drill bit, and then chambered in the usual manner using the appropriate calibre of chamber reamer.

A .32 calibre bullet will be a good press fit in a barrel machined to a bore diameter of 7.5mm. For the .380 round, a drill diameter of 8.7 or 8.8mm should be used. *The expedient barrel is far easier to make.* It consists of a two component assembly, i.e. a length of high strength seamless tubing, reinforced with a series of shaft lock collars. The collars are of the same size, i.e. ½", as those we have just bolted

to the inside of the upper receiver tube. The barrel tube is a 9" length of 14.29 x 3.25mm seamless mechanical tubing, (SMT). The 'SMT' and 'SHT' category of tubes are used quite extensively for industrial applications and are of perfectly adequate strength for the improvised firearm barrel. The collars not only reinforce the barrel, but also increase the barrels outside diameter, so allowing the barrel to be installed in the upper receiver. Before we fit the collars, the barrel must be chambered to accept the .32 calibre cartridge, (*See Appendix 'E' for the .380 calibre*). To chamber the barrel, a 'chamber reamer' will be required, (*See Appendix 'C' for supplier list*). First, the barrel must be firmly secured in a vice. Place the square shank of the reamer in a suitable tap holder and then slide the reamer into the barrels bore. Proceed to rotate the reamer in a clockwise direction, while applying light forward pressure to the reamer. A small amount of 'cutting compound' should also be applied to the reamers cutting edges, to ensure a smooth finish to the inside circumference of the chamber walls. Remove the reamer at intervals during the chambering process and carefully clean out the barrels bore with a wire cleaning brush. When a cartridge will chamber to a depth where 3mm of the cartridge base protrudes from the barrels breech, the chamber is cut to the correct depth. The reason for this protrusion will become apparent later when we begin to assemble the machine



Photo 29: The base of the cartridge must protrude 3mm from the barrel

pistols breech block, (See Photo 29). Following the chambering process, the chamber mouth must be chamfered, (bevelled), using either a countersink cutting tool or a de-burring tool. The purpose of chamfering the entrance to the chamber is to permit the smooth feeding of cartridges from magazine to barrel. The chamfer should be cut so it measures about 1mm to 1.5mm across (arrowed), (See Figure X). Finally, remove any metal shavings, etc, from the inside of the chamber and bore, and check that a cartridge will chamber smoothly under its own momentum.

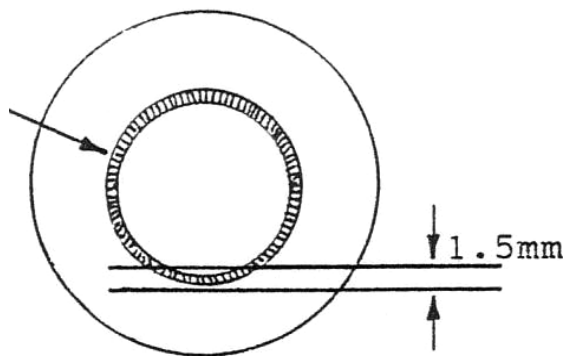

FIGURE X.

No force should be required to chamber the cartridge, and it should slide smoothly into the chamber. After cutting the

chamber mouth bevel and checking the cartridge fit, we can begin to assemble the barrel.

The barrel is fitted with six ½” collars, these are the same size as those bolted inside the upper receiver. We already have one barrel collar bolted inside the receiver, to the right of the ejection port. This is removed from the receiver and placed over the *chamber* end of the barrel. This collar has already been reamed out to an ID of 14.2mm ($\frac{9}{16}$ ”) and should be a snug press fit over the barrel. Five more collars must now be reamed out, using the same 14.2mm taper pin reamer we used earlier in Chapter Six. Slide two collars onto the barrel, behind the barrel retaining collar, and the other three in front of the retaining collar, (*Photo 30*). Use a hexagon key and thoroughly tighten the grub screws on each of the five collars. It is important to put the retaining collar over the barrel the *same way round* as it was inside the receiver. If it is not, it will not be possible to bolt the barrel to the receiver. Insert the assembled barrel into the receiver and bolt it in place with the four socket screws removed earlier, (*Photo 31*). With the barrel in position, make sure it is secure and does not move or revolve. Very little ‘play’ should exist between the tube and collar assembly. If, after reaming out, the collars will not slide onto the barrel, the barrel may be polished with sandpaper until the collars will slide on smoothly. It is well worth pointing out here that if $\frac{9}{16}$ ”

Expedient Homemade Firearms

collars can be located (with an outside diameter of 25.40 or 26 mm) they will slide straight onto the barrel without the need to ream them out. If available, seven $\frac{9}{16}$ " collars will be required, six for the barrel assembly and one to the left of the ejection port. Personal experience has

shown, however, that while $\frac{1}{2}$ " collars are readily available, those in non-standard fractional sizes are usually harder to locate. However, it is well worth asking for $\frac{9}{16}$ " collars when purchasing the other materials as they may be available in your area.



Photo 30: The fully assembled barrel.



Photo 31: The barrel fitted to the receiver.

8

BREECH BLOCK

As shown in the previous chapter, it is not necessary to own a lathe to make a gun barrel, and similarly, a milling machine is not required to construct the breech block, or 'Bolt', as it is commonly called. The normal method of bolt construction would be to machine it from a solid section of steel. For most would-be gun makers, this method will be out of the question. However, if we only include those sections of the bolt that are strictly necessary, and ignore those which are not, a 'skeletonized' bolt can be quickly assembled from a length of tubing and a series of shaft lock collars, an assembly very much like the barrel, in fact.

If you do own a lathe, or know someone who does, the bolt can be easily turned as a one piece unit, (See Appendix 'F' for machinist drawings). To assemble an 'expedient bolt', a 130mm (5 1/8") length of 12.70 x 2.03mm (1/2" x 14 g) SMT/SHT or ERW tube is required. First, the tube is cut to length and each end is filed completely flat. A tube cutter, (available from any store), is an accurate method of ensuring each end of the tube is as flat as possible. Use the cutter to make a shallow ring around the tube, and then file down to the ring mark. By using this simple method,

we can achieve accuracy usually only available to the lathe owner. At one end of the tube a slot is now cut, 32mm in length and 3mm wide, using a slitting wheel mounted in an angle grinder. The slot is then trimmed to the correct dimensions using a needle file, (See Figure Y). Don't worry if the slot is slightly less than this 3mm measurement, it does not matter too much. If an angle grinder is not available, a series of inter-connecting holes may be drilled to remove most of the steel before the slot is filed to its correct dimensions. This slot is the 'Ejector Slot', into which the 'Ejector Bolt' will fit in due course. We will discuss this simple part in the following chapter.

The ejector slot end of the tube is now 'countersunk' using a hand drill fitted with a 'taper cutting tool', (do not use a countersink cutter as this will cut the wrong degree of taper), (See Photo 32). The purpose of the tapered wall recess, as we will now call it, is to make the feeding of cartridges from magazine to chamber a more reliable process. If the taper cutting tool is not available to you, the recess may be cut straight walled, using a 9mm drill bit for the .32 bolt, and a 9.7 or 9.8mm for the .380. It should be noted, however, that if drills are used to cut the recess it must be done before the ejector slot is cut.



Photo 32: A taper cutting tool

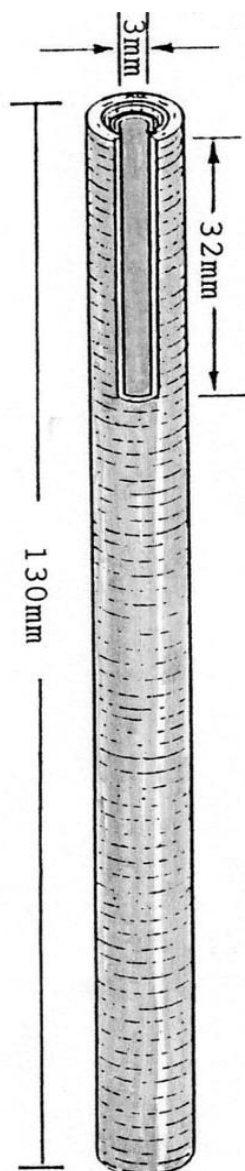

FIGURE Y.

The recess accepts the base of the cartridge, which, you may remember protrudes 3mm from the breech face of the barrel, (See Figure Z). The recess is cut just deep enough to allow the cartridge base to 'seat' to a depth of 2mm, and no further, (See Appendix 'E' for .380 bolt dimensions). The 'firing pin rod' can now be fitted inside the tube, it is 8.5mm in diameter and 31 mm long. Cut the rod to length, making sure each end is flat, and insert it into the tubes tapered end, (See

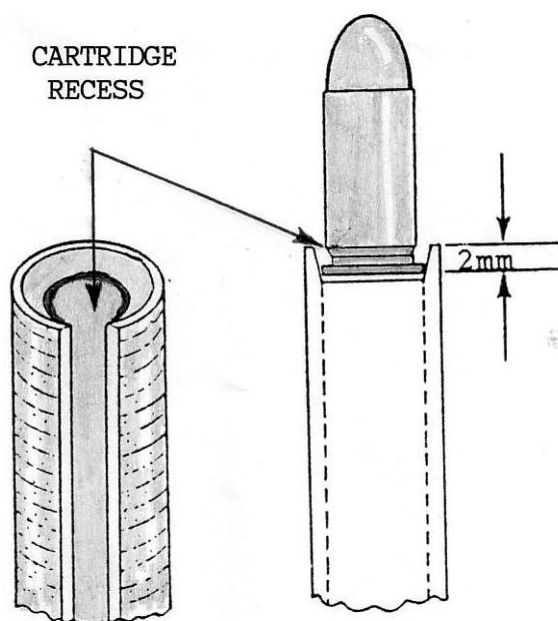

FIGURE Z.

Figure AA). Push the rod in until the top end of the rod is 2mm below the end of the tube. The rod is held in place by two steel pins. Drill two 2mm diameter holes through the tube and rod, and tap in two 2mm diameter pins, the pins being 1/2" in length. The first pin hole is positioned about 2mm above the end of the ejector slot and the second about 10 mm above the first hole. With the rod pinned in position, a 2mm deep tapered wall recess has been created, a recess that would normally be *machined* into the front face of the bolt. This area of the bolt is subjected to a great deal of pressure from the recoiling cartridge case, during the firing cycle. The two pins alone *are not* strong enough to withstand these pressures, so the rod must also be silver soldered for extra strength. As shown in Figure 'AA', the solder is applied to the gap between the rod and the inside of the tube. Use low

melting point silver solder in conjunction with flux and a propane gas torch. The two pins should be tapped out and the rod removed. Thoroughly coat the rod and pins with flux paste, then re-insert them into the bolt tube. Heat the top 1" or so of the rod and tube assembly until it is glowing a light red colour and then apply the solder. It is preferable to allow as much solder as possible to flow between the rod and tube, but do not apply so much that it overflows onto the top of the rod itself. Silver solder will only flow onto, and adhere to, surfaces that have first been treated with flux. Therefore, make sure no flux is present on top of the rod before starting to heat the tube. After soldering, allow the tube to cool, but do not quench it in water. Polish the tube with sandpaper to remove any flux residue and remove any surplus solder with a file.

We have already cut the ejector slot but now we must increase its depth by an extra 1.5mm. This can be done by using one of the large power hacksaw blades, or three standard blades, taped together. Run the blade back and forth inside the slot until the required depth is achieved. A good place to find used power hacksaw blades is your local engineering shop. Look through the scrap bins and you should be able to find one or more, perfectly good enough for this purpose. The next step is to drill a 1.5mm diameter hole in the top centre of the firing pin rod to a depth of between 10 and 12mm. This hole accepts the firing pin which is made

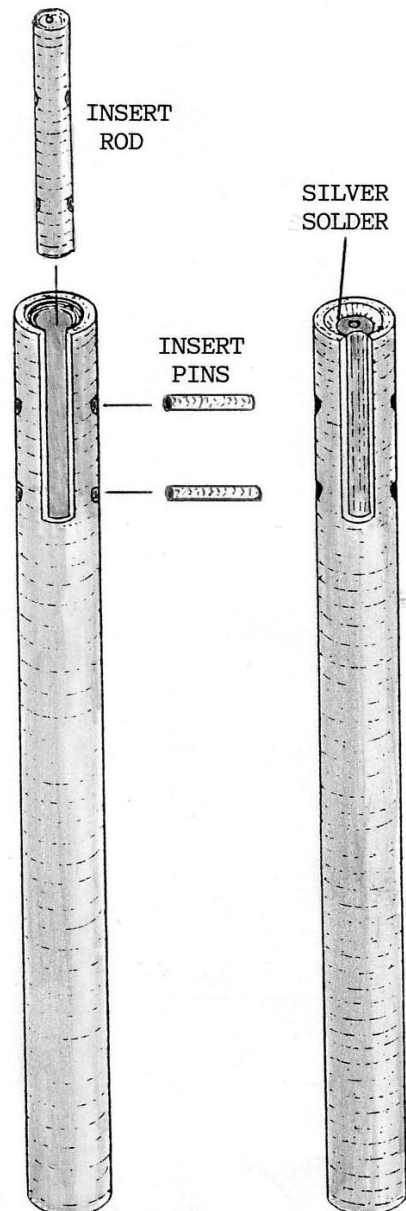

FIGURE AA.

using the shank of a 1.5mm drill bit. Drill the hole to a specific depth, say for our example, 12mm. The firing pin must protrude 1mm from the top of the rod face and therefore, the firing pin should be 13mm in length. In other words, the pin must be *1mm longer than the depth of the hole into which it is being inserted*. Use a grit stone and shape one end of the pin to a slight taper. Apply a drop of 'Loctite' bearing adhesive into the pin hole and insert the firing pin. Now leave the entire

Breech Block Assembly

assembly until the adhesive sets. Always check, and double check, that the pin is correctly adjusted to the protrusion measurement before permanently gluing the pin in position. If the pin is incorrectly set, the weapon will either fail to fire or the pin will snag on the cartridge base as the cartridge slides from magazine to chamber. This can cause the weapon to jam or make the firing cycle erratic and unreliable. Seven collars are now placed over the finished tube assembly, as shown in Figure 'BB'. These are the same size as those used for the barrel, i.e. 1/2" and will slide straight on without any modifications. However, on one of the collars, drill a 5mm diameter hole directly opposite the grub screw, through the collars side wall. Tap this hole so it will accept a 6mm diameter socket screw around 18mm in length. Slide all seven collars over the tube from the end opposite the ejector slot, the third collar being that drilled with the extra hole. Stack the collars so they are completely flush with the end of the tube and then tighten the grub screws. The 6mm socket screw acts as the bolt handle and can now be screwed into the modified collar, (Photo 33). If we look at the front face of the bolt, directly into the recess, the ejector slot should point to the *three o'clock position* and the bolt handle to *ten thirty* (Figure CC). The fully assembled bolt can now be inserted into the receiver. Remove the bolt handle and slide the bolt into position. Now screw the bolt handle back into the bolt through the bolt handle slot. Look through the ejector

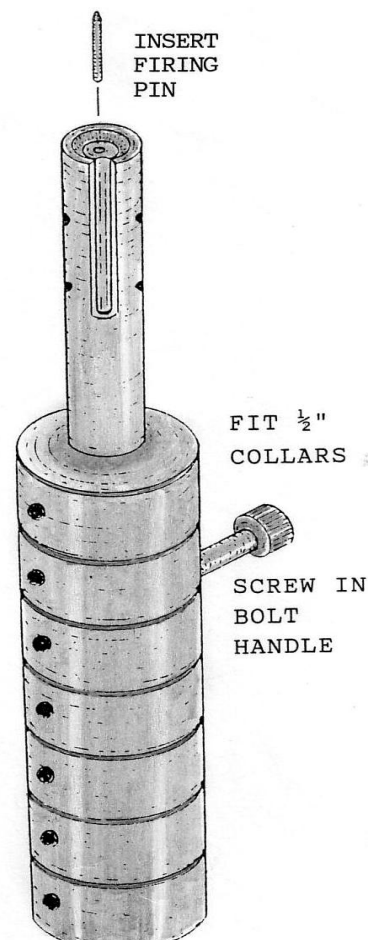

FIGURE BB.

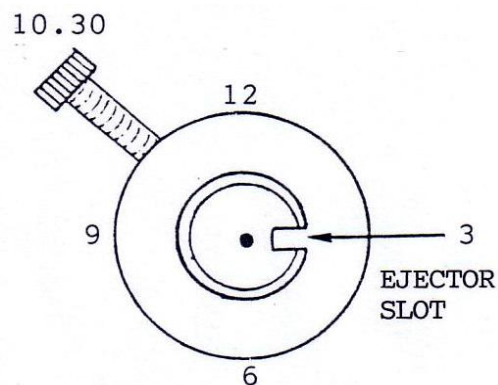

FIGURE CC.

hole in the left side of the receiver wall, and check that the ejector slot is visible, and, in correct alignment with the hole. If necessary, adjust the bolt handle position until alignment is achieved. Now firmly tighten the bolt handle, (Photo 34). The gap between the breech face of the

barrel and the front face of the bolt should now be checked. This measurement is important, and generally speaking, it should be possible to insert a piece of thin card between the two surfaces. The gap ensures that the bolt does not slam into the breech face if the weapon is 'Dry Fired', i.e. without a cartridge in the chamber. By moving the stack of collars forward slightly, the gap may be increased, or moved backwards for the opposite effect, if necessary.

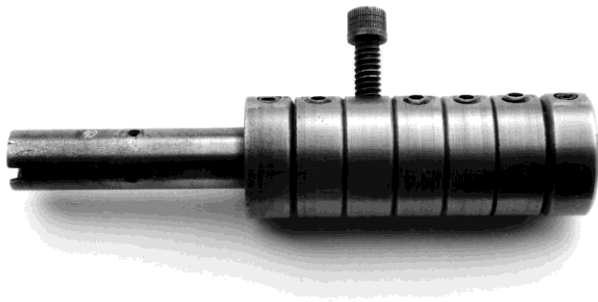

Photo 33: The fully assembled bolt.
Note position of ejector slot in relation to bolt handle.



Photo 34: The Bolt installed in the fully assembled upper receiver.

9

THE EJECTOR

The ejector is the part of the automatic firearm that 'Kicks' the spent cases out through the ejection port during the firing cycle. With very few exceptions, the ejector usually consists of a simple blade that connects with the base of the cartridge as the recoiling case drives the bolt rearwards; thus flicking the case out of the firearm through the ejection port.

We will make the ejector from a 6mm diameter socket screw $\frac{1}{2}$ " in length. The end of the screw is filed into a 2mm thick blade for a length of about 5mm. One edge of the blade is then filed to a taper, so the opposite edge is made into a point as a result, (See Figure 'DD').

The ejector is now inserted into the ejector hole and retained in position with a nut. Before the nut is tightened, the ejector must be positioned so the *pointed side* of the ejector is facing the chamber. Once the ejector is in position, slide the bolt back and forth several times, checking that it does not bind or snag on the ejector. The tip of the ejector should almost scrape the bottom of the ejector slot, a small amount of hand fitting may be required to achieve this. If the ejector is too long it will bind on the bolt, and if it is too short, will not eject the cases when the weapon is discharged.



Photo 35: The Ejector Bolt and nut.

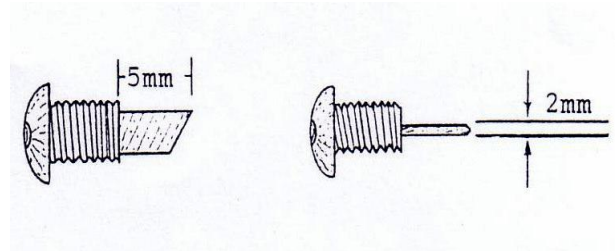

Although the ejector is very simple, its correct length is essential, (See Photo 35)

FIGURE DD

10

MAINSRING



Photo 36: The spring coiling machine.

The mainspring must be the correct length, strength and diameter. If the spring is too strong, the cartridge will generate insufficient pressure to cycle the action, and turns the automatic into a single shot firearm. If the spring is too light, it may not absorb as much recoil force as necessary. This may result in excessive strain on the action or even a breech explosion, as the bolt opens too soon. As I pointed out in volume one, trying to find the correct strength, length and diameter of spring can be difficult. For this reason, coiling our own mainspring may be a necessity. This is, however, far easier than it may at first appear.

To coil the spring we require a 14 ft length of the same 20 gauge spring wire used for the magazine spring. Before we can coil the spring, a simple spring coiling machine must be built. The machine consists of only three parts; a 25" length of 19.05 x 5mm ($\frac{3}{4}$ " $\frac{3}{16}$ ") flat bar, a 23 $\frac{1}{2}$ " length of

5.5mm rod and a steel collar. It is perfectly possible to build the entire machine in under one hour and makes coiling a spring a simple procedure, (See Figure 'EE').

First, drill a 5.5mm ($\frac{3}{16}$ ") diameter hole $\frac{1}{2}$ " from each end of the bar. Then 4 $\frac{3}{4}$ " from each end scribe a straight line. Clamp the bar in a vice and heat the area of this line using a gas torch until the steel is glowing a red colour. Bend the end of the bar at this position into a right angle and then repeat this same procedure at the opposite end of the bar. The base section of the machine is now ready to be fitted with the mandrel, around which the spring is coiled. This is a 23 $\frac{1}{2}$ " length of 5.5mm steel rod. At one end of the mandrel drill a 1.0 or 1.5mm hole through the rod, 1" from the end. Bend the opposite end of the mandrel into two right angles to form the winding handle. It will be necessary to insert the mandrel into the base and mark the position of the two bends before bending the handle to shape. By using a gas torch to heat the rod at the points where the two bends are to be made, the handle is easily formed with a pair of pliers. Insert the mandrel into the base and secure it in place with a steel collar. Turn the handle and the mandrel should revolve smoothly. The machine is now clamped in a vice and we are ready to coil the mainspring, (Photo 36). Insert the wire through the hole and bend the end into a knot to prevent it from pulling out. The length of spring wire must be placed

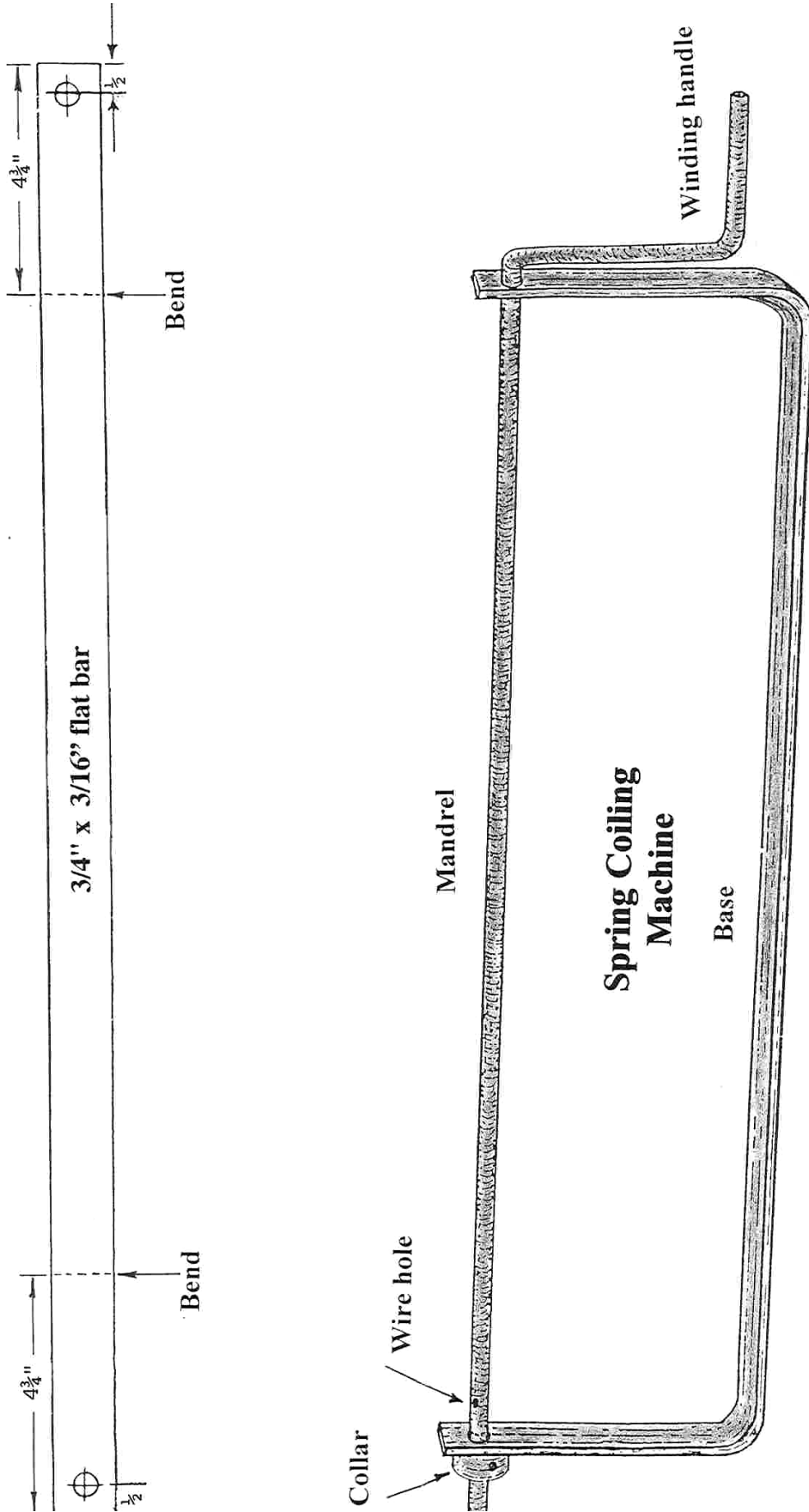

FIGURE EE.

under constant pressure to coil the spring. The easiest method is to stand on it with both feet, leaving both hands free to guide the wire and turn the handle. Use the left hand to hold the wire at a slight angle while turning the handle. Continue turning until the spring is coiled along the entire length of the mandrel. A gap of 4 mm, or thereabouts, should exist between each coil. This gap can be increased or decreased during coiling by holding the wire on a greater or lesser angle. The first three or four coils will dictate the angle at which to hold the wire, before coiling the remaining length. The mandrel should bow out slightly during coiling to indicate that sufficient tension is being applied to the wire. Snip through the knotted section and any excess wire and, with the spring still on the mandrel, compress it fully several times. After the spring has been compressed it will be noticed that the spring has shrunk in length from 16" to about 11". Remove the mandrel collar and slide the mandrel out of the machine to release the spring. Now snip the spring to a length of 9 ½" using a pair of pliers.

The mainspring is now finished and ready to be fitted to the spring guide rod, (See Figure 'FF'). The guide is a 114mm length of 5mm diameter rod. One end is rounded, (tapered), and the other fitted with a 6mm collar. The collar is positioned 7mm from the end of the rod.

Slide a 1" diameter rubber tap washer onto the tapered end of the guide and push it up until it is touching the collar

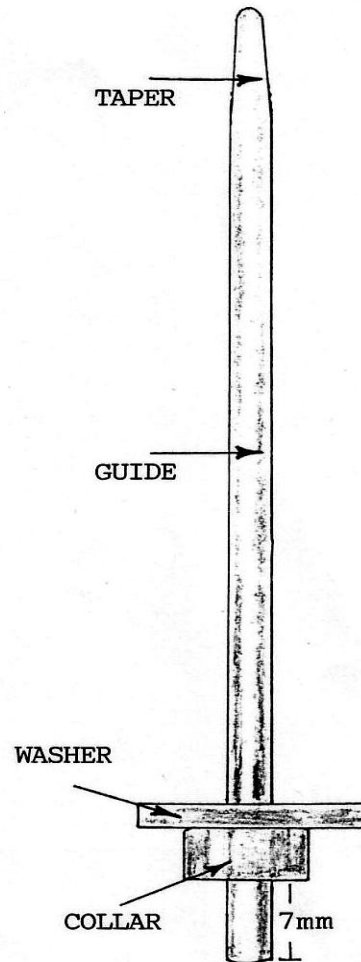

FIGURE FF.

With the mainspring and guide rod constructed we can build the recoil shield, which is responsible for holding the bolt, guide and spring in position.

RECOIL SHIELD

The collar fitted to the breech end of the upper receiver already acts as the recoil shield, but must be modified one step further. A 2" diameter 'mud wing washer' must be bolted to the collar as a means of sealing the breech of the receiver. The washer should have a 6 or 7mm hole. Mud wing washers come in many different sizes and are widely available from bolt

and nut stockists, and good hardware stores. First, remove the collar from the receiver and temporarily bolt the washer to the collar, as shown in Figure 'GG'. The collar must be bolted as *centrally* as possible to the washer. Another washer, any diameter over 1", is placed at the other side of the collar so the collar is sandwiched between the two washers. Thoroughly tighten the nut and bolt and then drill two 3mm diameter holes through the 2" washer and all the way through the collar, (Figure 'HH'). These two holes must be positioned *between the four socket screw holes* (these allow the collar to be bolted to the receiver). Accuracy of drilling the collar is very important. If the holes are drilled in the wrong places they will either cut through into the screw holes or pass too close to the inside or outside wall of the collar. The latter making it difficult to tap the holes; which is the next step. Run a tap through each hole and bolt the washer to the collar, as shown in Figure 'II'. Now insert the collar and washer assembly into the breech of the receiver and secure it in place with the four socket screws. Use a scribe and mark the inside face of the washer using the walls of the receiver as a guide. Unscrew the bolts and remove the washer and it will be marked with a square, as shown in Figure 'JJ'. Place the washer in a vice and file each side down to the scribe lines until it is square in shape, as shown in Figure 'KK'. Lightly remove any sharp corners on the washer then securely bolt the square washer to the collar, as in Figure 'LL'.

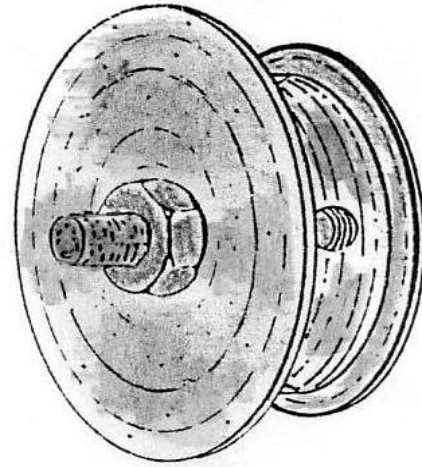

FIGURE GG

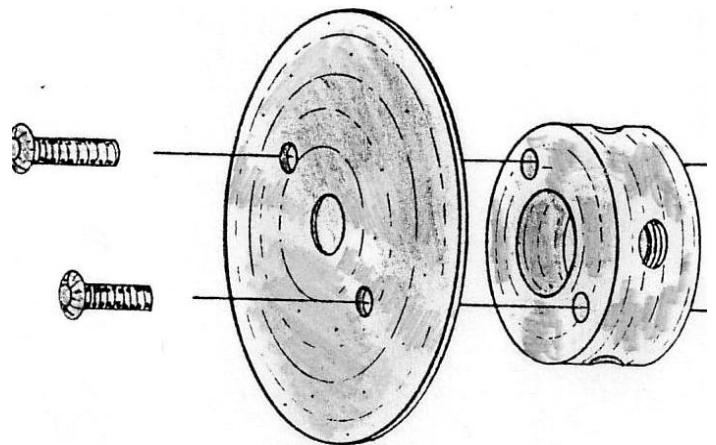

FIGURE HH

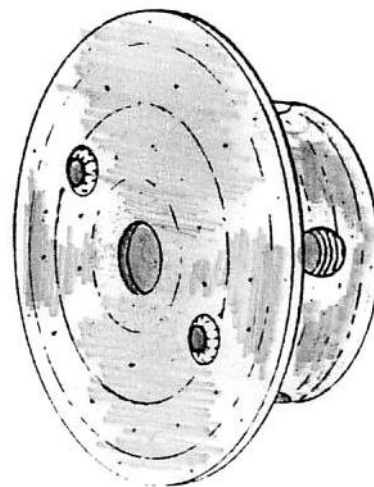

FIGURE II

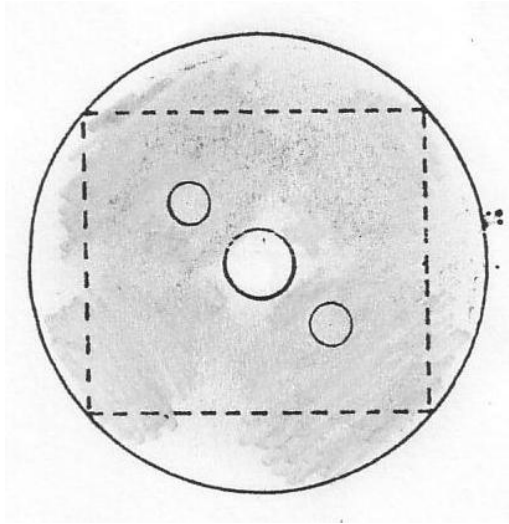

FIGURE JJ.

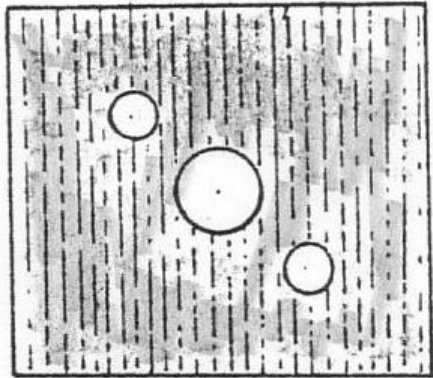

FIGURE KK

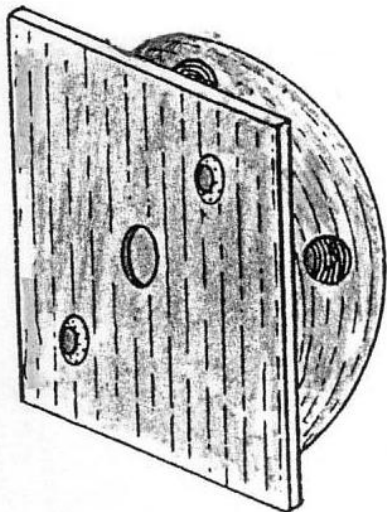

FIGURE LL.



Photo 37: The fully assembled recoil shield.



Photo 38: The recoil shield, mainspring and guide rod.

The recoil shield is now finished and can be unbolted from the receiver, to allow the spring and guide to be fitted, (*Photo 37*). Slide the spring onto the guide rod and then insert this assembly into the recoil shield, (*Photo 38*). Pull the bolt *fully back* and hold it in this position. Hold the shield and guide assembly in the palm of the hand and use your fingers to hold the spring in the half compressed position. While holding the bolt back, insert the spring and guide into the hollow middle of the bolt (mainspring recess) until the shield is fully inserted. Let the block slide forward to release the tension on the compressed mainspring, then screw in the four socket screws to retain the recoil shield, spring and guide rod in position, (*Photo 39*).

Pull the bolt back several times and check that it moves smoothly without binding or snagging on any part of the spring and guide assembly.

The upper receiver is now fully assembled (Photo 40)

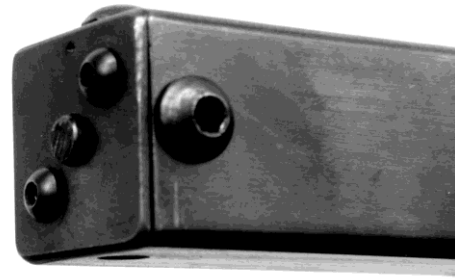

Photo 39: The recoil shield fitted to receiver.



Photo 40: The fully assembled Upper Receiver.

NOTE: If the bolt mainspring is coiled around the 5.5mm diameter mandrel described earlier, the mainspring should be a smooth sliding fit through the centre of the bolt. However, due to the inevitable inconsistencies that can creep into the

spring coiling process, you may find that the spring is slightly tight when inserting it into the bolt. If this is encountered, the mainspring recess can be enlarged slightly using an 8.8mm diameter drill bit.

11

ASSEMBLING

The two complete receiver assemblies can now be bolted together and the necessary adjustments made, (*Photo 41*). Remove the two socket screws from the underside of the upper receiver and place the two receivers together. The two halves should fit closely together with no gap visible between them. However, it may first be necessary to lower the height of the magazine well slightly, so the feed ramp does not interfere with the underside of the Bolt. Insert the two socket screws and bolt the two sections firmly together, (*See Figure 'MM'*). The well and magazine stop have not yet been permanently fixed in place. This is to allow their correct adjustment, which is not possible until the weapon is fully assembled. The magazine lips should touch the underside of the bolt, but should not prevent it from moving smoothly back and forth. If necessary, push the magazine further into the well until the lips are in the correct position. Remember, the stop is loose and will allow the magazine to be moved higher or lower as necessary. The well must also be adjusted so that the front tip of the feed ramp touches the underside of the bolt, but again, must not interfere with the bolts smooth movement. With these two adjustments made, the well and stop can

be silver soldered in place. Be careful not to disturb the two settings, then separate the two receivers. Remove the magazine and strip it of all internal parts. Now unbolt and remove the spring catch from the magazine well. Use a propane gas torch in conjunction with flux and low melting point silver solder to retain the well and stop in position. Apply the solder to the underside of the stop so the solder does not interfere with inserting the magazine back into the weapon. Do not apply too much solder, only a few drops are required to hold the stop in position. Propane gas torches and canisters are widely available from most good hardware stores. The gas canisters may be sometimes referred to as 'propane/butane mix' and are ideal for silver soldering because the mix of gases give a far higher temperature than a standard butane torch. Flux must be applied to the area where the solder is required to run, and then heated until the steel is glowing a light red colour. While keeping the torch in position, touch the soldering rod against the hot steel until the solder flows. After the required amount of solder flows into the joint, remove the torch flame and allow the part to cool slowly. Once the part is cool, clean off any flux residue and excess solder with a file and then polish using a medium grade sandpaper. The magazine well is soldered along its top side edge, at the point where it passed through the upper recess. Re-assemble the magazine and attach the catch spring to the well. We can now bolt the two receivers back together.

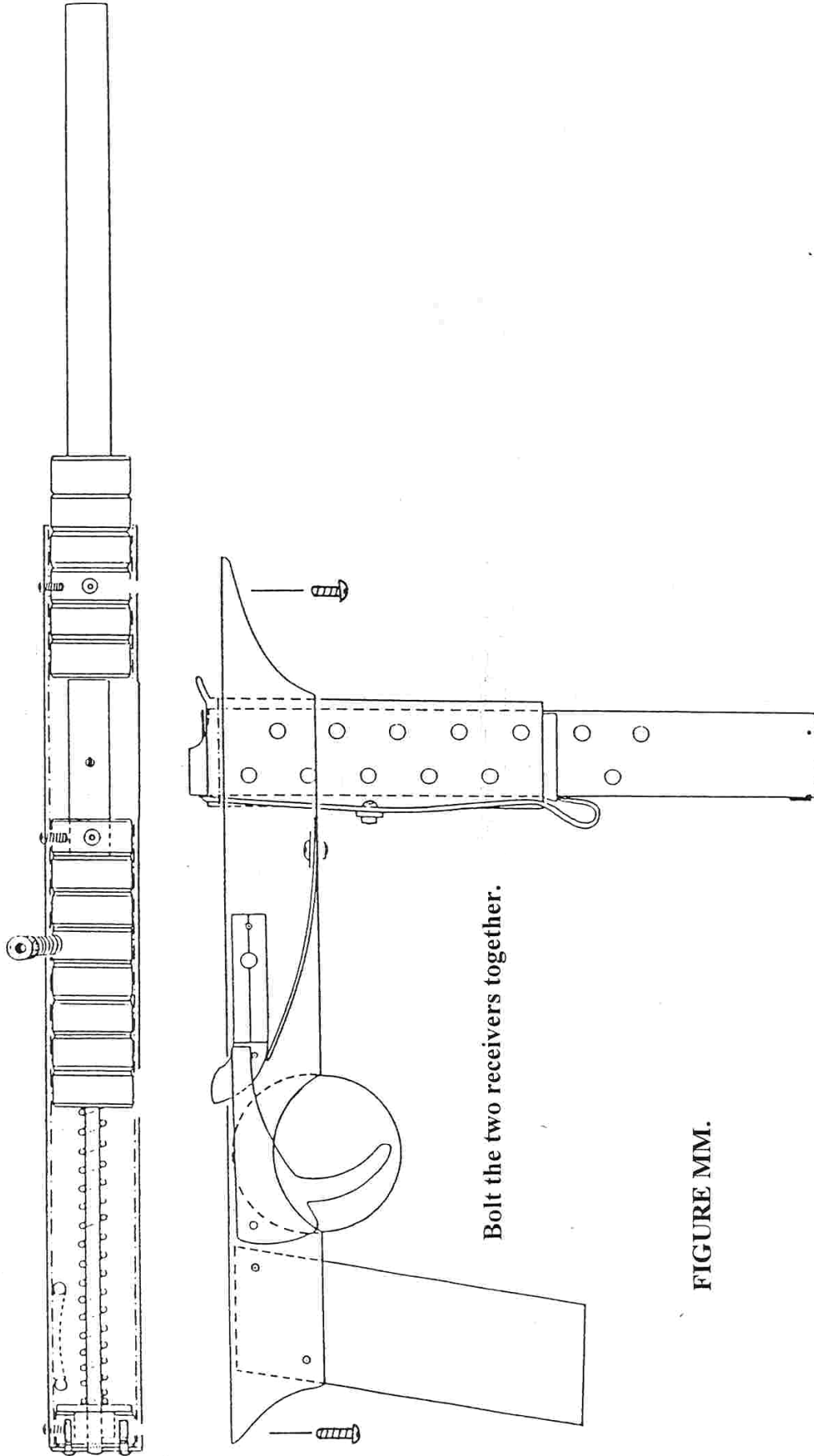

Bolt the two receivers together.

FIGURE MM.



Photo 41: The upper and lower receivers ready to bolt together.

12

MAKING A SLING

A suitable sling is a very important accessory on any firearm larger than a handgun, as a means of easily carrying the weapon. Obviously, if a sling is available commercially, buying one is simpler than making one. But, as with the firearm itself, we will assume that this is not possible and making one is necessary. Let's face facts, the crackpots in power these days are banning guns, knives and any other scapegoat objects that they wish. These power crazy nutters might ban slings and holsters too. They'll claim it will stop criminals carrying guns!!

A perfectly suitable sling can be made from a 4 ft length of dog lead, or one of the longer reins used for horses, cows, etc. These are readily available from any pet, equestrian or farming supply store and are made from exactly the same material as a purpose-made rifle sling. I prefer canvas, but leather or nylon serves just the same purpose. The lead or rein should be 1" to

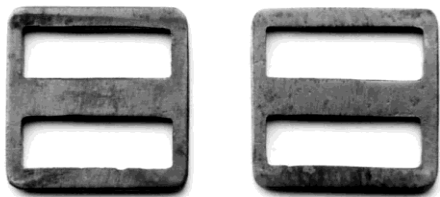

Photo 42: Sling buckles.

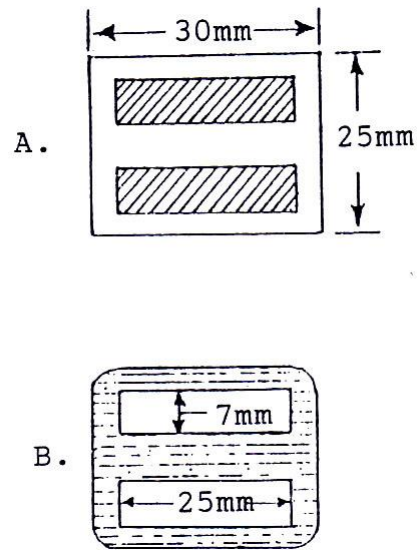
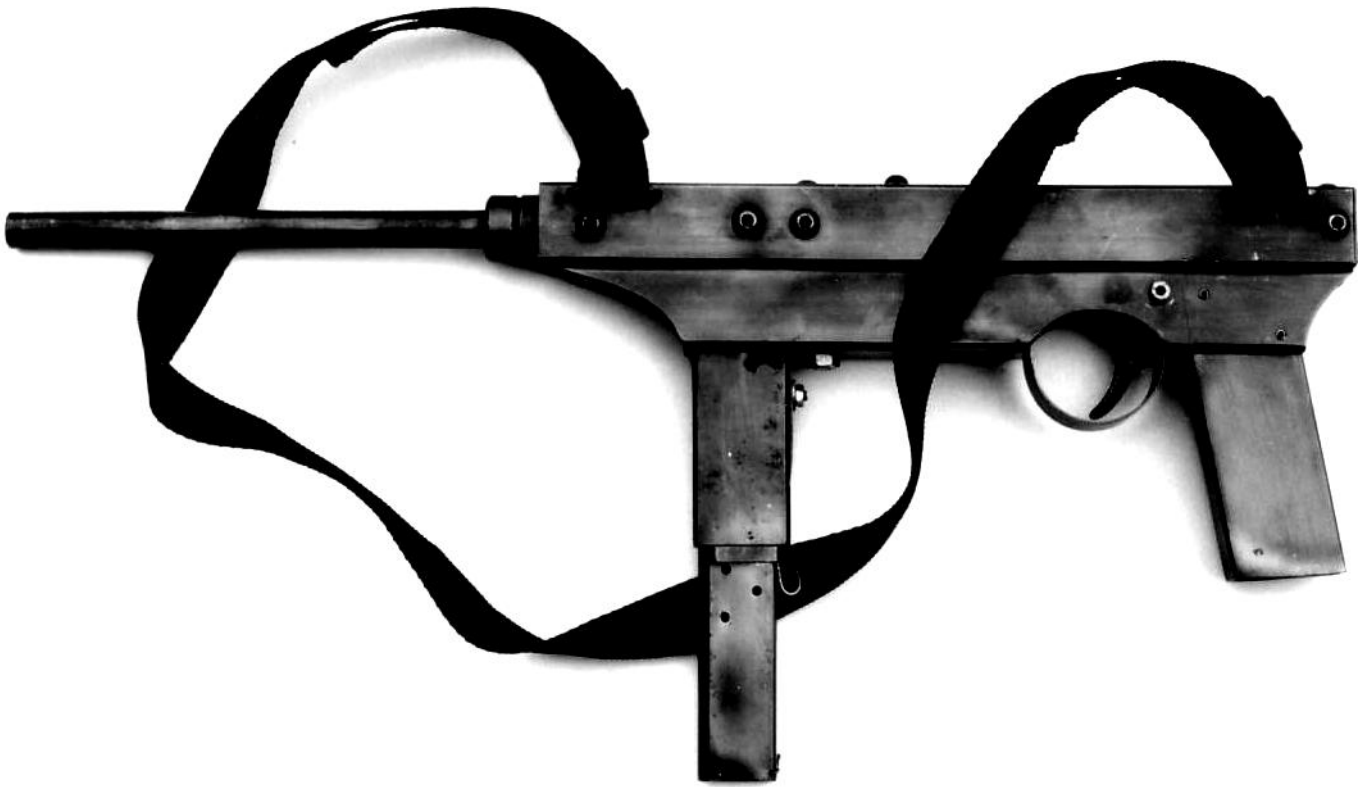

FIGURE NN.

1¹/₈" wide and be black or dark green in colour. Two buckles must now be made to attach the sling to the weapon. These are made from a 30 x 25mm section of 2mm thick steel plate, (See Figure 'NN'). Drawing 'A' shows the shaded sections that must be removed. Use a drill to remove the two unwanted sections and file the two rectangular holes to the dimensions in Drawing 'B'. Round the four corners with a file and polish every edge and surface of the buckle with sandpaper, (Photo 42). This polishing is important because any sharp or rough edges could fray or cut through the sling material over a period of time. Don't worry if the buckles you make are not exactly the same size as those in the illustration, it is only necessary for the sling to feed into the buckle holes.

Now adjust the sling length to suit your own personal requirements.



Right and left side views of the fully assembled firearm.

13

FINAL FINISHING

For reasons of picture clarity, the machine pistol, seen through the pages of this book, is shown in its final finished appearance. The firearm at this stage would still have its raw metal appearance, so we will discuss here the expedient method of finishing.

The hot gun bluing process used in the arms factory, or by the professional gunsmith, has no place in a book like this. Not only would special chemicals be required, but bluing tanks and heating apparatus also. We have seen how a machine pistol can be constructed at home from commonly available materials. It is only right to finish the weapon using the simplest home applied method.

One of the best looking gun finished I have found is to 'colour case harden' each component part of the firearm. This can be done using nothing more than a gas torch. This method is not true case hardening, but does give a similar and extremely good looking finish. With the exception of the bolt, sear and springs, all parts are finished using the following method.

All visible external surfaces must be sanded to a smooth polished finish using a fine grade of sandpaper. The better the finish is before applying the blow torch, the better the finish will look afterwards.

As I pointed out earlier, it is far easier to polish the parts after each part is made, rather than having to finish every section of the weapon at this stage.

First we will finish the upper and lower receivers. Remove all internal parts from the upper receiver with the exception of the ejector. Place the receiver in a vertical position on a steel plate or other fireproof surface. Apply the torch flame to the top end of the receiver, holding it in this position until heat rings appear on the surface of the steel. This should happen in around 30 seconds assuming a propane gas torch is used. Don't move the flame around, but hold it on the same point until the steel is seen to change colour. Now move the flame further down the receiver and, at every 2" interval, repeat the process described above. When the entire side of the receiver is 'heat treated', turn the receiver around and carry out the same procedure on the other three sides. The lower receiver is finished in exactly the same way. Do not remove the grip as it can be left in place, but make sure all internal moveable parts are removed. The magazine must also be stripped before the magazine body can be finished. The barrel assembly can be finished as a complete unit without having to remove the collars, but because of the heavy gauge of tube and thickness of the assembly, heating the steel will take longer. Small sections, such as the trigger and guard, are finished in just the same

way as the larger components. Obviously the firearm could be finished using one of the cold gun blue finishes available from any gun shop, but the way things are going there may not be many gun shops left before too long! Besides, the heat treatment method of finishing is more durable and, in my opinion, better looking. If you do decide to use the cold bluing method, I would advise buying the liquid version of the product. It should be noted, however, that the cold gun blue liquid will not cover up any deep scratch marks present on the guns external surfaces. Whichever method of finishing is used, it will only look as good as the amount of effort you put in beforehand. Note also, that many hardware products such as

shaft lock collars and washers are often zinc plated, and the zinc will interfere with the bluing process. However, the zinc can be easily removed with a quick soak in Hydrochloric Acid. Leave the items in the acid solution until the items stop 'bubbling'. This indicates that all the zinc has been removed. As a means of preventing the formation of rust, the parts can then be soaked in a hot baking soda solution (soda and hot water) before proceeding to blue the parts. The barrel and bolt assemblies do not need to be dismantled and can be submerged in the two solutions fully assembled. Whichever process is applied to finish the external surfaces of the machine gun, the resulting finish should prove to be a pleasing one.



Colour image showing finished firearm.

14

TEST FIRING

I know what you are thinking; “*WILL IT BLOW UP?*” The answer to this understandable question is a positive *NO*, provided the weapon is built using the same materials and construction methods described in this book. However, with any homemade firearm, it is only wise to test fire the weapon with single shots before filling the magazine to maximum capacity and pulling the trigger!! Firing single shots first also makes it easier to see what, if any, adjustments are required. Initially, load one round into the magazine and cock the weapon. Point the firearm in a safe direction and squeeze the trigger. The cartridge should fire and the spent case should be ejected through the port. Repeat this procedure, but this time, load three cartridges into the magazine and squeeze the trigger. The weapon should fire a rapid burst. Provided no jams are experienced, the magazine is loaded to maximum capacity and one long burst

may be fired; discharging the magazine. The trigger can be release at any time during the firing cycle and the sear should lock the bolt back in the fully cocked position.

Most .32/.380 automatic firearms have a very high cycle rate, and the expedient machine pistol is no exception to this rule. A fully loaded magazine will empty in around two or three seconds, so the rpm is not to be sneezed at. It is rather expensive on the ammunition front though. Full metal jacket (FMJ) ammunition must be used for the weapon to function reliably. The barrel length is also important because a length of less than 9” will not generate sufficient pressure to reliably cycle the bolt, so don’t be too enthusiastic with the hacksaw.

The Expedient Firearm is not intended (or designed) to compete with the factory made firearm in either looks or the quality of materials used. It is a compromise weapon of last resort; available when most legitimate and conventional firearms have been legislated away, as in the authors country of residence. However, for all intents and purposes, the Expedient Machine Pistol is a viable firearm if constructed with a reasonable degree of care and attention to detail.

A'

MACHINE PISTOL TUBE SIZES

The tube sizes shown below are those required to construct the major component parts of the Machine Pistol, i.e. receivers, barrel, magazine and bolt, etc.

- 1) 30 x 30 x 2mm (Upper Receiver)
- 2) 30 x 30 x 1.6mm (Lower Receiver)
- 3) 25.40mm x 12.70mm + 12.70 x 0.91 mm (1 x 1/2" + 1/2" x 20g) (Magazine)
- 4) 14.29mm x 3.25mm SMT (Barrel)
- 5) 12.70mm x 2.03mm (1/2" x 14g) SMT/SHT/ERW (Bolt)
- 6) 15.88mm x 34.93mm x 1.6mm ERW (Magazine Well)
- 7) 40mm x 20mm x 1.6mm ERW (Grip)
- 8) 50.80mm x 1.6 mm (2" x 16g) (Trigger Guard)

The ERW tubing is very useful for the construction of receivers and magazines or as sleeving to reinforce or increase the diameter of another tube. It should not be used for gun barrelling, unless nothing else is available, due to its welded seam construction. The SMT and SHT category of

tubes are ideal for the construction of the improvised firearm barrel. Because of the many different tube sizes available in 'seamless mechanical' and 'seamless hydraulic' tubing, it is possible to construct a gun barrel to suit almost any calibre of firearm. Where possible, heavy gauge tubing can be used for gun barrels, providing the design of the firearm will allow it. However, there is no reason why a lighter gauge of tubing cannot be used to construct a gun barrel, but it may be necessary to reinforce it with a second tube or a series of steel collars for extra strength. Tube manufacturers rarely give the bore size of tubing in their catalogues. Instead, only the tubes outside diameter and wall thickness are supplied. To calculate the bore size, the wall thickness must be multiplied by two, and this measurement deducted from the tubes outside diameter. For example, a wall thickness of 2.50mm is doubled and becomes 5mm. For a 14 x 2.50mm tube, the calculation would be as follows:-

Tube diameter 14 mm
Wall thickness 5 mm
Bore diameter = 9mm

B' IMPROVISED GUN BARRELS

Tube sizes for improvised firearm barrels from .22 rimfire to 12 gauge shotgun. Seamless Mechanical Tube (SMT) and Seamless Hydraulic Tube (SHT).

<u>CALIBRE</u>	<u>TUBE SIZE REQUIRED (mm)</u>	<u>BORE DIA (mm)</u>
<u>.22 Rimfire</u>	<u>9.53 x 2.03 (SMT)</u>	<u>5.47</u>
	<u>9.52 x 2.03 (SHT)</u>	<u>5.46</u>
<u>.25 ACP</u>	<u>12.70 x 3.25 (SMT)</u>	<u>6.20</u>
<u>.32 ACP</u>	<u>14.29 x 3.25 (SMT)</u>	<u>7.79</u>
<u>.38/.357</u>	<u>15.88 x 3.25 (SMT/SHT)</u>	<u>9.38</u>
	<u>19.05 x 4.88 (SMT)</u>	<u>9.29</u>
<u>9mm/.380</u>	<u>14.29 x 2.64 (SMT)</u>	<u>9.01</u>
	<u>14.00 x 2.50 (SHT)</u>	<u>9.00</u>
	<u>15.00 x 3.00 (SHT)</u>	<u>9.00</u>
<u>.44/.410</u>	<u>20.64 x 4.88 (SMT)</u>	<u>10.88</u>
	<u>19.05 x 4.06 (SMT)</u>	<u>10.93</u>
<u>.45 ACP</u>	<u>17.46 x 2.95 (SHT)</u>	<u>11.56</u>
<u>12 Gauge</u>	<u>26.99 x 4.06 (SMT)</u>	<u>18.87</u>
	<u>28.58 x 4.06 (SMT)</u>	<u>20.46</u>
	<u>28.00 x 4.00 (SHT)</u>	<u>20.00</u>
	<u>30.00 x 5.00 (SHT)</u>	<u>20.00</u>

All the tube sizes listed here offer an excellent 'Bullet to Bore' fit. All will require chambering with the appropriate calibre of chamber reamer.

C' CHAMBER REAMER SUPPLIERS

The following list of suppliers ship high quality 'chamber finish reamers' world-wide. Prices do vary, but at the time of writing, Chamber reamers start at around \$35 (£20) for a .22 rimfire reamer. For the machine gun featured in this book, a reamer in either .32 or .380 auto is required. These retail at around \$55. There are numerous chamber reamer suppliers available through the Internet, of which the list below is only a small example:-

USEFUL ADDRESSES:

DAVID MANSON PRECISION REAMERS

820 EMBURY ROAD,
GRAND BLANC, MI 48439,
USA.

{Tel: 810 953 0732

{Fax: 010 953 0735

Email: David@mansonreamers.com

www.mansonreamers.com

CLYMER MANUFACTURING CO,

1645 WEST HAMLIN ROAD,
ROCHESTER HILLS, MI 48309,
USA.

{Tel: 248 853 5555

{Fax: 248 853 1530

Email: clymer@clymertool.com

www.clymertools.com

SHAWNIE TOOLS,

840 NW 6TH STREET, SUITE F,
GRANTS PASS, OR 97526
USA.

{Tel: 541 471 9161

E-mail: reamers@att.net

www.reamerrentals.com

D' HOMEMADE REAMER

I would strongly recommend the use of a professionally ground reamer to cut the chamber of any barrel. However, if it is necessary to build your own reamer, the following method can be used. Unlike the chamber we cut in volume one, using a taper pin reamer, the straight walled case of the .32 and .380 cartridges means that an improvised chamber can be cut using a series of three drill bits. For the .32 chamber we require one, 7.8mm drill and two, 8.5mm, and, for the .380, a 9mm drill and two 9.5mm in diameter. Whichever of the two calibres it may be necessary to cut a chamber for, the only difference is the diameter of the drills used, all other measurements remain the same. We will proceed as if cutting the chamber for the .32 cartridge. First, three 78mm, or thereabouts, lengths of 14.29mm barrel tube are required, (See Figure 'OO'). We will call these the 'Reamer Tubes' from now on. The inside diameter (ID) of each of the three tubes must first be reamed out using the three drill sizes given above, i.e. one tube is reamed out to a diameter of 7.8mm, and the remaining two tubes to a diameter of 8.5mm. As can be seen in the accompanying drawing, reamer tube No1 accepts the 7.8mm drill and the No2 and No3 tubes the 8.5mm drills. For the .380 chamber the No1 tube accepts the 9mm drill and the No2 and No3 tubes the 9.5

mm drills. After reaming out the tubes, a hole must be drilled to accept a socket screw in the position shown in the accompanying drawing. The purpose of the socket screw is to hold the drills firmly in position. Only one drill, the 8.5mm (9.5mm for the .380), requires any alteration before the 'reamer set' can be used to cut the chamber. The point of this drill must be removed, and in so doing, create a flat ended cutting tool. This can be achieved quite easily by touching the end of the drill point against the spinning wheel of a bench grinder, while at the same time, slowly rotating the drill so the point is evenly removed. It is worth pointing out that if a drill press is available to you, the point of the drill can be accurately removed by simply putting the drill in the drill chuck and lowering the spinning drill onto a grit (Carborundum) stone, however, most of the drill point will still need removing first, using the bench grinder, before using the drill press method of finishing the end of the drill.

The two cutting edges of the flat ended drill must now be re-sharpened by carefully 'touching' the back edges of the two cutters against the wheel of a bench grinder. This procedure is similar to re-sharpening the point of a drill, except for our purposes, the end of the drill is now a

FIGURE 'OO' REAMER CONSTRUCTION.

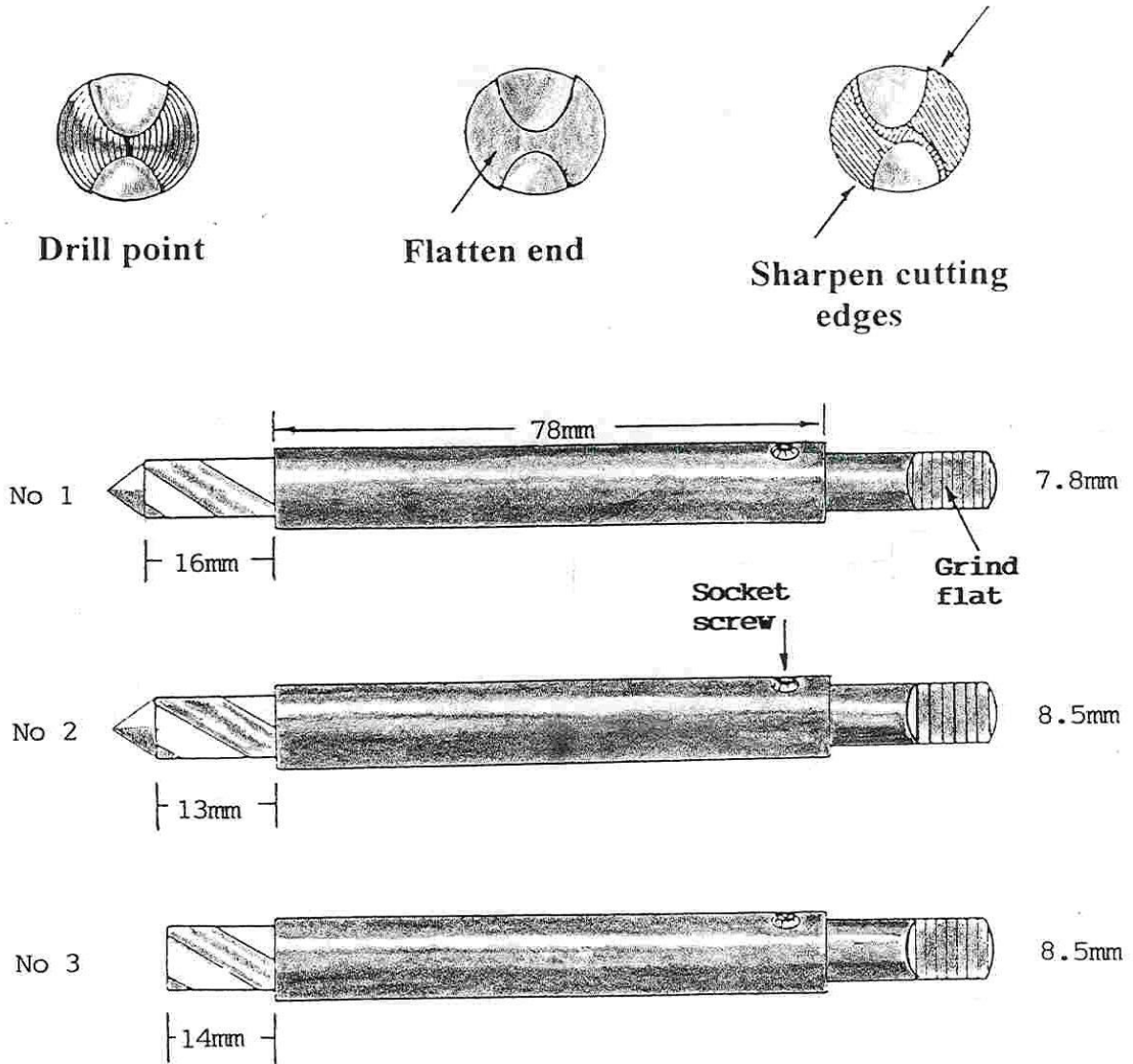

Homemade Reamer

flat ended cutting tool. Place each drill in it's respective reamer tube and adjust the No1 drill until it protrudes 16mm from the end of the reamer tube,(excluding the drill point). Now adjust the No2 and No3 drills to 13mm and 14mm respectively. The drill measurement is the same for both the .32 and .380 calibres. When each drill is adjusted to the measurements given above, tighten each socket screw to prevent the drills from moving during use. A flat side must now be ground onto the side of each drill shank so they can be turned using a standard 'tap wrench/Holder'. Before the reamer set can be used a guide tube is required to ensure the chamber is accurately cut. This is nothing more elaborate than a 6 ½" to 7" length of 20.64 x 2.95 mm tubing.

Our improvised reamer set is now ready for use. To cut the chamber proceed as follows. Firmly clamp the barrel tube in a vice at roughly a 45 degree angle to the vice jaws and slide the guide tube over the end of the barrel. Now slide the No 1 reamer drill into the guide tube as shown in the accompanying *Photos, 45 and 46*.

Each reamer drill is used in the order it is numbered, i.e. one, two and three. Apply a small amount of cutting compound, if available, to the tip of each reamer and proceed to cut the chamber. Slowly turn each reamer while at the same time applying a small amount of forward pressure until each reamer has cut fully to it's respective depth. At intervals during the cutting operation, clean out any metal shavings from the inside of the chamber.

After using the last (No3) reamer, place the No1 reamer back in the barrel tube and rotate it several times. This will be necessary to remove any burring present in the bottom of the chamber, caused by the use of the flat ended No3 reamer tool. Finally, using a wire barrel cleaning brush, remove any metal shavings etc, from inside the barrel and chamber.

The chamber is now cut and it should be possible to slide a cartridge into the chamber. The cartridge must slide in *freely* and under its own momentum before coming to a stop. At this point the base of the cartridge should protrude *3mm* from the barrels breech, as we saw earlier in Chapter Seven.

After checking the cartridge fit and cutting the chamber mouth bevel, we can proceed to re-assemble the barrel.

The improvised chamber reamer is not the ideal method of cutting the chamber of a firearm, but it will suffice if a professionally ground chamber reamer is, for any reason, unavailable. It is worth pointing out, however, that the genuine article is so widely available, that it is well worth investing in one. They are relatively inexpensive and make the chambering of any gun barrel a quick and easy operation.



Photo's 45 and 46: The three piece reamer tool; and above, fitted to the barrel ready to cut the chamber.



Note the flat ended No3 reamer tool; shown third from left.

E' **.380 CONVERSION**

The machine pistol featured in this book can also be built around the popular .380 auto pistol cartridge with only slight modifications being required to the magazine, bolt and barrel. It is only down to individual requirements as to which calibre the firearm is chambered.

The barrel is constructed using exactly the same principals described in Chapter Seven. The only difference being the size of tubing used. A length of 14.29 x 2.64 mm SMT tubing is required to construct the .380 barrel. The tube should be 9" or 10" in length and chambered to accept the .380 cartridge using the appropriate calibre of chamber reamer. When chambered, the base of the cartridge must protrude 3mm from the barrels breech. The chamber mouth is chamfered in exactly the same manner as described for the .32 barrel. The shaft lock collars are then reamed out and fitted to the barrel. The .380 barrel is now finished and can be fitted to the receiver.

There are two other tube sizes that may be used for the .380 barrel, in the event of the 14.29 x 2.64mm tubing being unavailable. These are the 14 x 2.50mm and the 15 x 3.00mm tubes. Both offer a bore size of exactly .380 (9mm), and either one is a perfectly good alternative for the machine pistol barrel. However, if either of the

above tubes are used, the collars will require reaming out using a reamer of 14 or 15mm diameter respectively.

MAGAZINE ASSEMBLY

The magazine construction for the .380 cartridge is identical to that for the .32, the only difference being the gauge of tube used to construct the magazine and the distance between the magazine lips. The magazine well, follower, and mainspring should not require any alterations. We require a length of 1" x 1/2" tubing for the .380 magazine with a wall thickness of either 1.22 or 1.50mm (instead of the 1.6mm used for the .32 magazine). The second tube, the 1/2" (12.70mm x 0.91mm) remains the same for both calibre magazines. The slightly thinner gauge used for the .380 magazine increases the magazines inside dimensions and as a result, the magazine will accept the .380 cartridge.

The magazine lips are formed using the same form block used for the .32 magazine, except the lips for the .380 must be 'set' so the distance between them is approximately 9mm. A certain amount of hand fitting should be expected for whatever calibre magazine we are building, to ensure it functions as reliably as possible.

BOLT ASSEMBLY

Only one alteration is required to the bolt assembly for it to accept and function using the .380 cartridge. This alteration being the cartridge recess dimensions discussed in chapter eight. Assuming we are building a .380 bolt, it is only necessary to increase the cartridge recess diameter (fractionally) using the taper cutting tool, so as to allow the base of the .380 cartridge to recess (seat) to a depth of 2mm, as illustrated in chapter eight. It should be noted that this modification can only be carried out during the first stage of bolt assembly, and *not* after the firing pin rod has been fitted.

The firing pin protrusion measurement is the same as for the .32 cartridge, i.e. 1mm from the face of the cartridge recess.²

THE EJECTOR

The ejector should not require any alteration to either its length or width. However, a small amount of hand fitting may be required.

TUBE SIZES REQUIRED FOR THE .380 BARREL, BOLT AND MAGAZINE.

BARREL 14.29 x 2.64mm SMT (or
14 x 2.50 / 15 x 3.00)

BOLT 12.70 x 2.03mm SMT/SHT/ERW

Magazine 25.40 x 12.70mm (1" x
½" x 1.22mm) (or 1.50mm) and
12.70 x 0.91mm (½" x 20gauge)
round tube.

² NOTE: The 'life span' of the .380 bolt is inevitably less than that of the .32 bolt. This is due to the reduction in the wall thickness of the .380 cartridge recess caused by the use of the larger diameter .380 cartridge. The .380 bolt will therefore require replacing at more frequent intervals.

F' .32/.380 BOLT DIMENSIONS

The drawings on following pages may be used if the bolt is to be machined using a lathe, (See *Figure 'PP'*). In the interest of ensuring the bolt is as strong and durable as is reasonably possible, we must machine it from a suitable steel. We do not want to harden and temper the bolt following machining, due to the inevitable 'technicalities' involved in doing so. Although hardening would be desirable, for the average hobbyist, it would be an unfeasible proposition. The actual size (diameter) of the bolt would necessitate the use of a suitable heat source such as a fire brick arrangement or a small furnace in which to heat the component to the required hardening and tempering temperatures. Not to mention the ability to use such techniques and equipment.

Small parts such as, for example, a sear, trigger or firing pin are quite easily heat treated using nothing more than a propane gas torch (available from any hardware store) and bucket of oil or water in which to quench the job. The larger component does pose problems for the average individual.

All is not lost however because steels are available in the pre-hardened and tempered conditions. In other words, the steel comes "off the shelf" in a pre-hardened condition, while at the same

time being 'soft' enough to machine. These steels are suitable for our requirements (and many others) where a reasonable degree of shock and wear resistance is required. Two pre-hardened steels I have found suitable (and that seem to be reasonably easy to locate) are 709M40 (EN19T) and 817M40 (EN24T). You will need to purchase such materials from a 'special steel stockholder', so look in the 'Yellow Pages' under 'Steel Stockholders' for a supplier in your area. Searching the 'Net' is also a good idea. Such steel is rather expensive in relation to, for example, a mild steel, especially if you have to have it delivered, but you may be able to purchase a short length as a 'sample' or 'off-cut'. Always check when purchasing such steel that it is in 'T condition' meaning it is sold in the pre-hardened state. Some steel manufacturers also advertise their own brands of 'special steels' in the pre-hardened condition, and if you decide to purchase one of these, you should ensure the steel is suitable for your purpose. Generally speaking, it must fall into the high tensile, shock and wear resistance category. The alloy steels I have listed are a good example of these requirements and are reasonably easy to locate.

Machining the bolt is a straight forward

Machinist Drawings

turning procedure for the lathe owner. Start with a section of round bar, at least 26mm in diameter, and machine the bolt to the following dimensions:-

Referring to Figure 'A', Outside diameters (OD) Bolt overall length (OAL) is 131mm. Front section (A1), turn to an OAL of 53mm and 13mm OD. Turn remaining length (A2) to an OD of 26mm, ideally.

Figure 'B': Using a 5.5mm diameter drill bit, the mainspring/guide recess (B1) is machined to a depth of 100mm. The recess is then re-bored to a depth of 74mm using a 9mm diameter bit.

Cartridge Recess. The cartridge recess (B2) is machined to a diameter of 9mm and a depth of 2mm.

Figure 'C': Ejector bolt slot. Machine slot (channel) to 32mm in length and 3mm width (C1). Slot depth is 4mm (C2). The slot may be machined at any point on the bolt radius at this stage.

Figure C3, Bolt handle position (looking into the cartridge recess). Drill bolt handle hole at a 45 degree angle adjacent to the ejector bolt slot to a depth of 6mm. Tap hole to accept a 6mm diameter socket screw.

Figure 'D', Firing pin hole. Drill to 1.5mm diameter (D1) and 12mm depth (D2). Pin consists of 1.5mm dia' drill shank 13mm in length. Retain the pin using bearing adhesive or similar product. Pin must

protrude 1mm from recess face when fully seated (D2).

Figure 'E', .380 bolt. All dimensions for the .32 bolt apply equally to the .380 bolt, except for cartridge recess (E1) 9.7mm to 10.0mm diameter, and front section (E2), 13.5 mm 'OD'.³

Figure 'F'. Position the bolt handle hole 50mm from the rear face of bolt.

³ Note: a certain amount of 'hand fitting' may be required to ensure the bolt will function reliably.

.32 BOLT DIMENSIONS

(All measurements in millimetres)

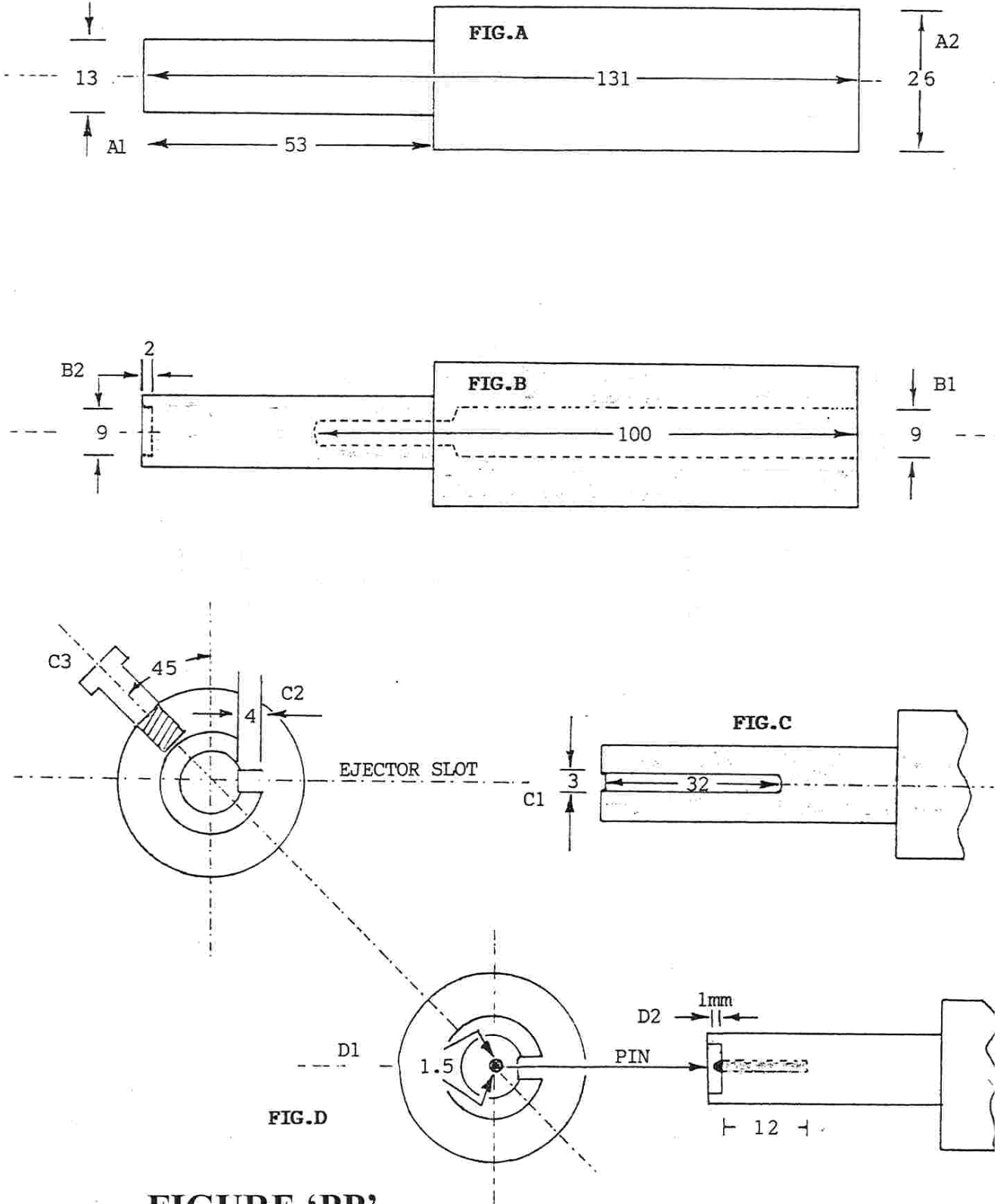

FIGURE 'PP'

.380 BOLT DIMENSIONS

(All measurements in millimetres)

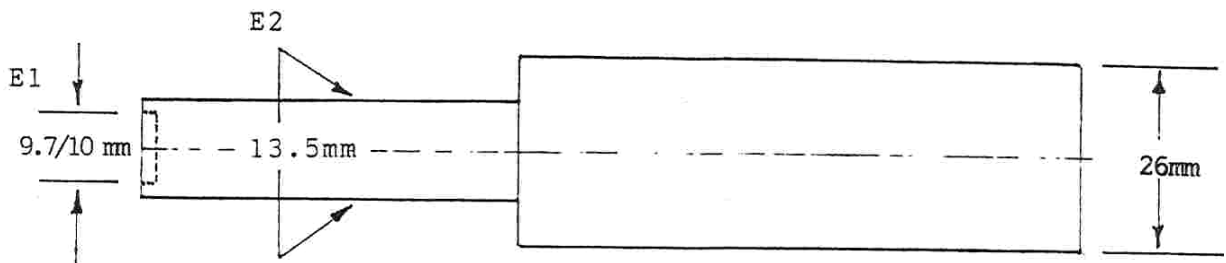

FIG. E

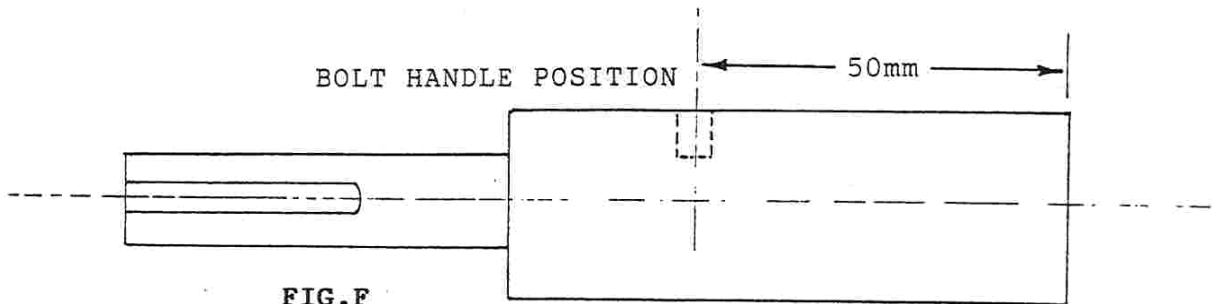
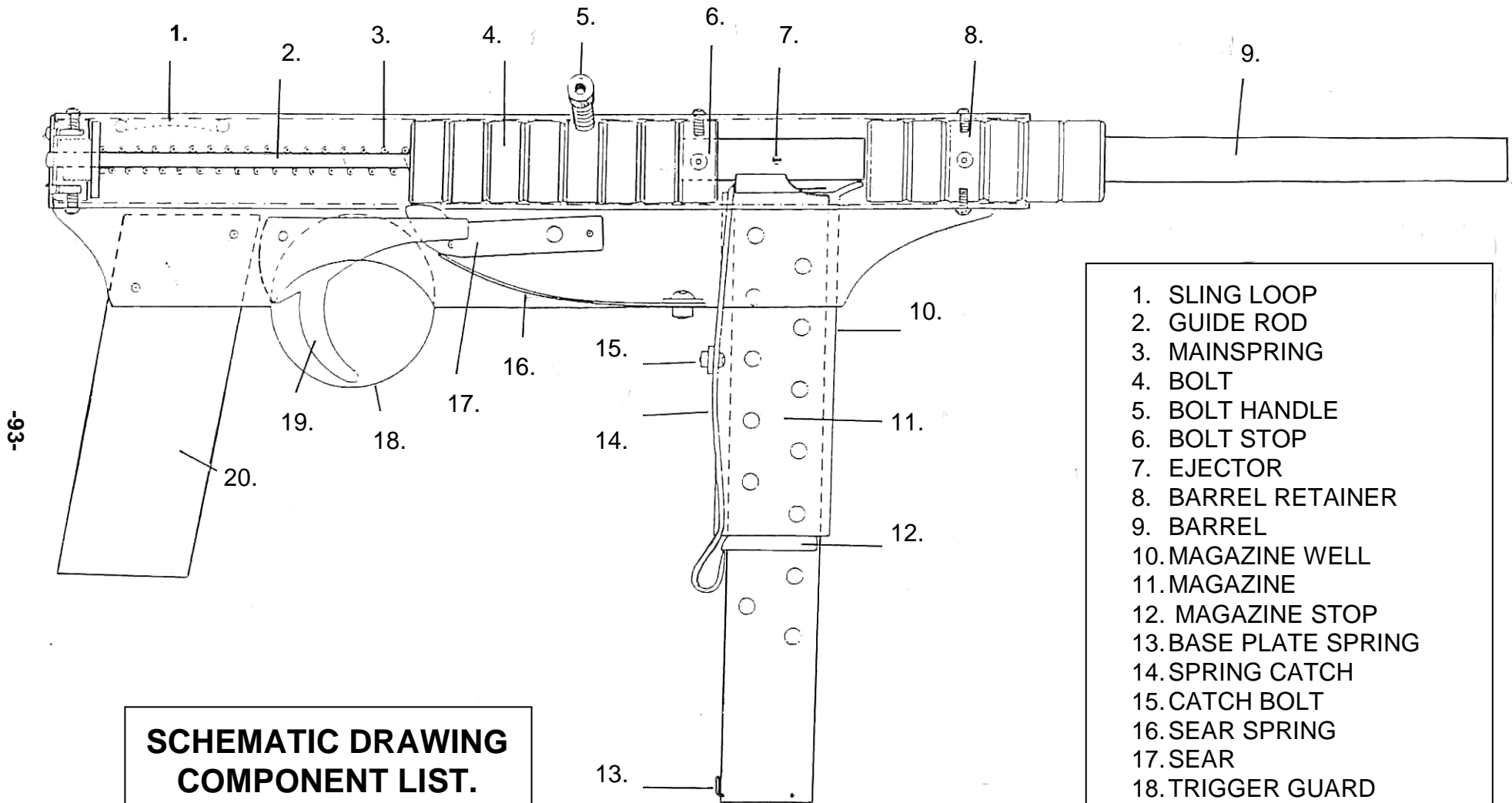

FIG. F



**SCHEMATIC DRAWING
COMPONENT LIST.**

- 1. SLING LOOP
- 2. GUIDE ROD
- 3. MAINSPRING
- 4. BOLT
- 5. BOLT HANDLE
- 6. BOLT STOP
- 7. EJECTOR
- 8. BARREL RETAINER
- 9. BARREL
- 10. MAGAZINE WELL
- 11. MAGAZINE
- 12. MAGAZINE STOP
- 13. BASE PLATE SPRING
- 14. SPRING CATCH
- 15. CATCH BOLT
- 16. SEAR SPRING
- 17. SEAR
- 18. TRIGGER GUARD
- 19. TRIGGER
- 20. GRIP

.32/.380 Machine Pistol Mk II

The following machine pistol design is similar to the .32/380 Machine Pistol, except for an alternative bolt and mainspring design and slightly different receiver dimensions. The firearm cannot be constructed entirely by hand but requires the use of a lathe to construct the bolt and recoil shield. However, the firearm is easier to build due to a simpler bolt design. The upper and lower receivers are constructed from the same 30 x 30mm tubing discussed earlier. The following plans are an alternative construction method:-

UPPER RECEIVER

The upper receiver is slightly longer at 11 $\frac{3}{4}$ " (298mm). The following drawings, (*Upper receiver recess positions*), illustrate the upper receiver recess dimensions.

LOWER RECEIVER

The lower receiver templates are used in the usual way and the recess positions marked. The lower receiver being 11 $\frac{1}{8}$ " (283 mm) in length. When the receivers are temporarily clamped together (using the two hose clips we used earlier), the breech end of the upper receiver must overlap the end of the lower by 6mm.

BOLT ASSEMBLY

The bolt is a simple assembly consisting of a 7" long section of $\frac{1}{2}$ " diameter high tensile bolt, and a series of six $\frac{1}{2}$ " shaft lock collars. The $\frac{1}{2}$ " bolt section should have a tensile strength of 12.9 ideally. First, remove the bolts head and thread, Figure 'A', and using a lathe, trim each end of the bolt until it has an overall length of 4 $\frac{3}{8}$ " (111mm), Figure 'B'. The cartridge recess and ejector slot are now cut (so suit calibre) into one end of the bolt section. At the opposite end, a series of six $\frac{1}{2}$ " collars, (Figure 'C') are fitted and retained with bearing adhesive or a similar product. The bolt handle is now screwed into the third collar from the rear of the bolt. The third collar remains moveable to allow the bolt handle to be adjusted as necessary to align with the bolt handle slot.

RECOIL SHIELD

The recoil shield is machined from a section of round bar. As shown in the illustration, (Page 8), the shield has an overall length of 68mm. A simple piece of ordinary mild steel is perfectly adequate for this. The shield is secured in position with four 6mm diameter socket screws.

MAINSRING

The mainspring cannot be successfully coiled by hand due to the heavy gauge of wire required to make the spring. There are two options available. The first is to locate and purchase a spring of the correct dimensions, and the second is to have a spring specially made. Many spring manufacturers hold large stocks of ready made springs, and it may be possible to find a spring of the correct dimensions. However, the second option is by far the easiest. Having a spring made may sound like an expensive option but the cost is quite reasonable, especially if the spring is made by one of the smaller manufacturers, who may even coil the spring while you wait or for next day pick up. The main cost in having a spring coiled is in the setting up of the machine, rather than in the cost of the material used. It is usually possible to have a one metre length of spring coiled (out of which we

can cut about six individual mainsprings) for about £15. This means that each spring costs less than £3 each, not bad for the firearms fourth most important component! Rather than spending time looking for the correct spring "off the shelf", it is far easier just to supply the required spring dimensions to the manufacturer and have the spring specially made. It is quick, easy and relatively cheap. For the MkII machine pistol we require a compression spring, 25mm in diameter (OD) and coiled from 15 gauge wire. The spring should be coiled from standard carbon steel wire. Once the length of spring has been acquired, it may be cut into 6" lengths, this being the correct length for use in the MkII machine pistol. Alternatively if you wish to spend a few pounds more, the manufacturer will automatically cut the spring into 6" lengths as it comes off the machine, saving you an extra job. Look under 'springs' and 'spring manufacturers' in 'yellow pages'.

MKII LOWER RECEIVER TEMPLATES

Note: This template is not drawn to scale and must be enlarged by 25% using a photocopier. After enlargement, the overall length of the template should be 282mm. If it is not, the template can be enlarged or reduced as necessary until the 282mm measurement is achieved.

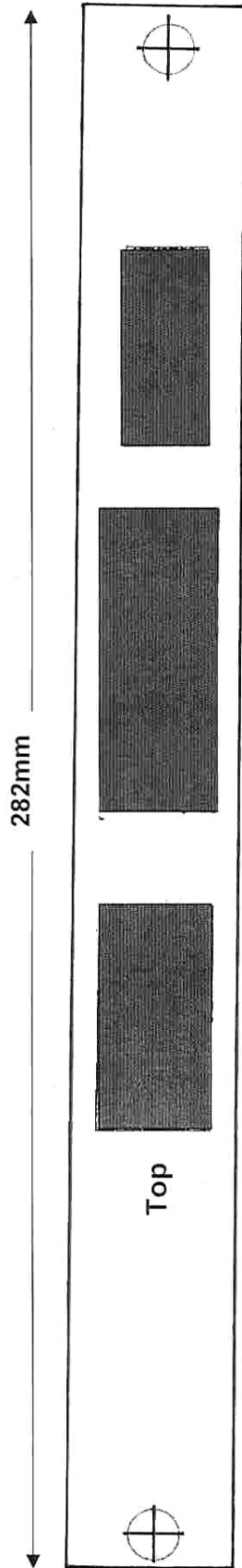

Cut out and remove shaded areas.
(Note: Hole diameters not to scale)

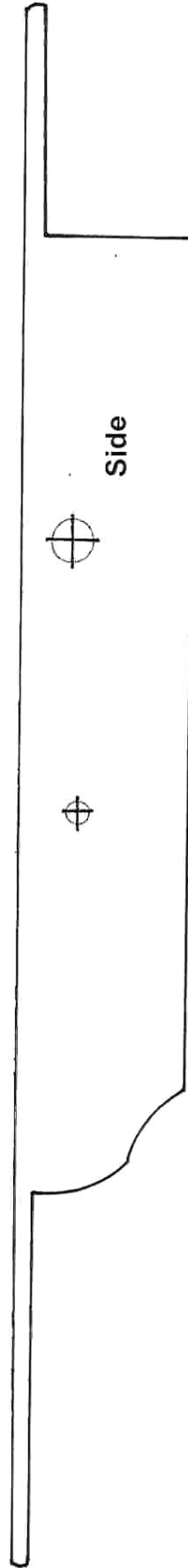

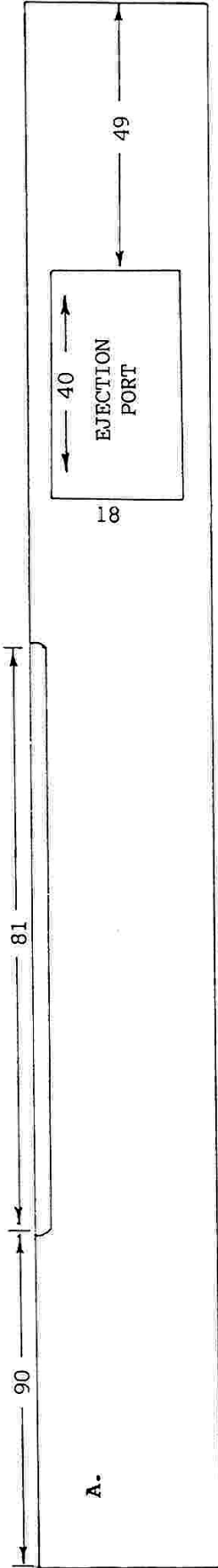

MK11 UPPER RECEIVER RECESS POSITIONS

(All measurements in millimetres)

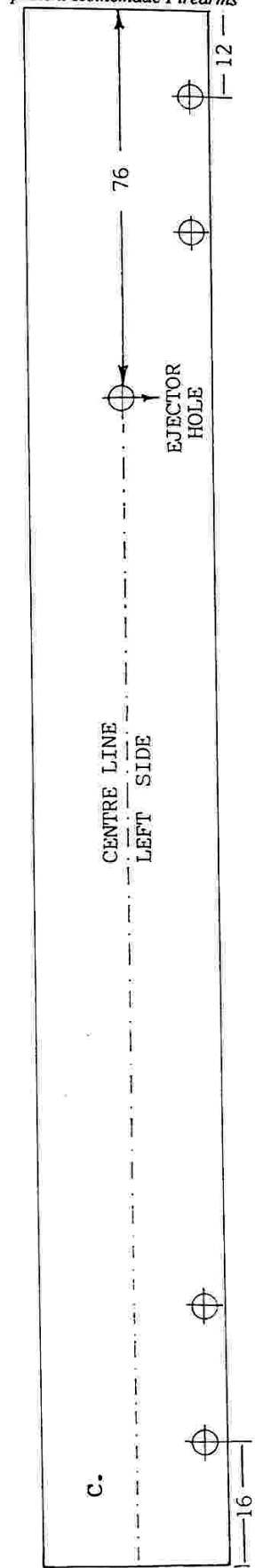
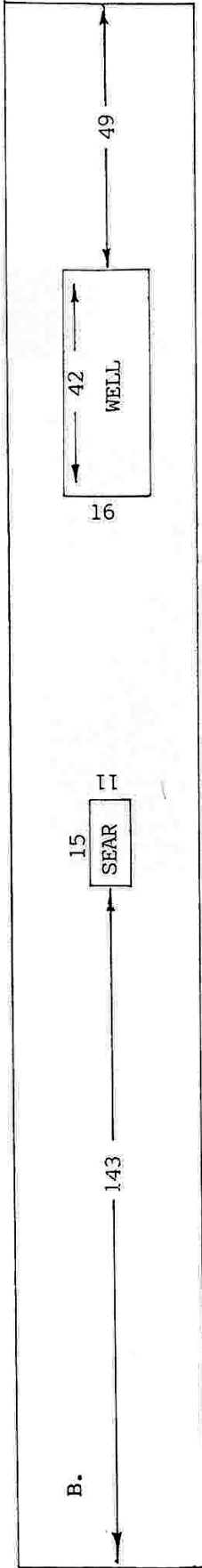

The upper and lower receiver assembly

(Measurements in millimetres)

With the upper and lower receiver assembly clamped together with two hose clips, the upper receiver must overlap the lower by 6mm, as shown at 'A'.

The slot for the trigger 'B', is positioned 58mm from the rear end of the receiver and is 17mm in length. The slot for the trigger guard, 'C', is positioned 51mm from the front of the receiver and is 3mm in length and 12.7mm (1/2") in width.

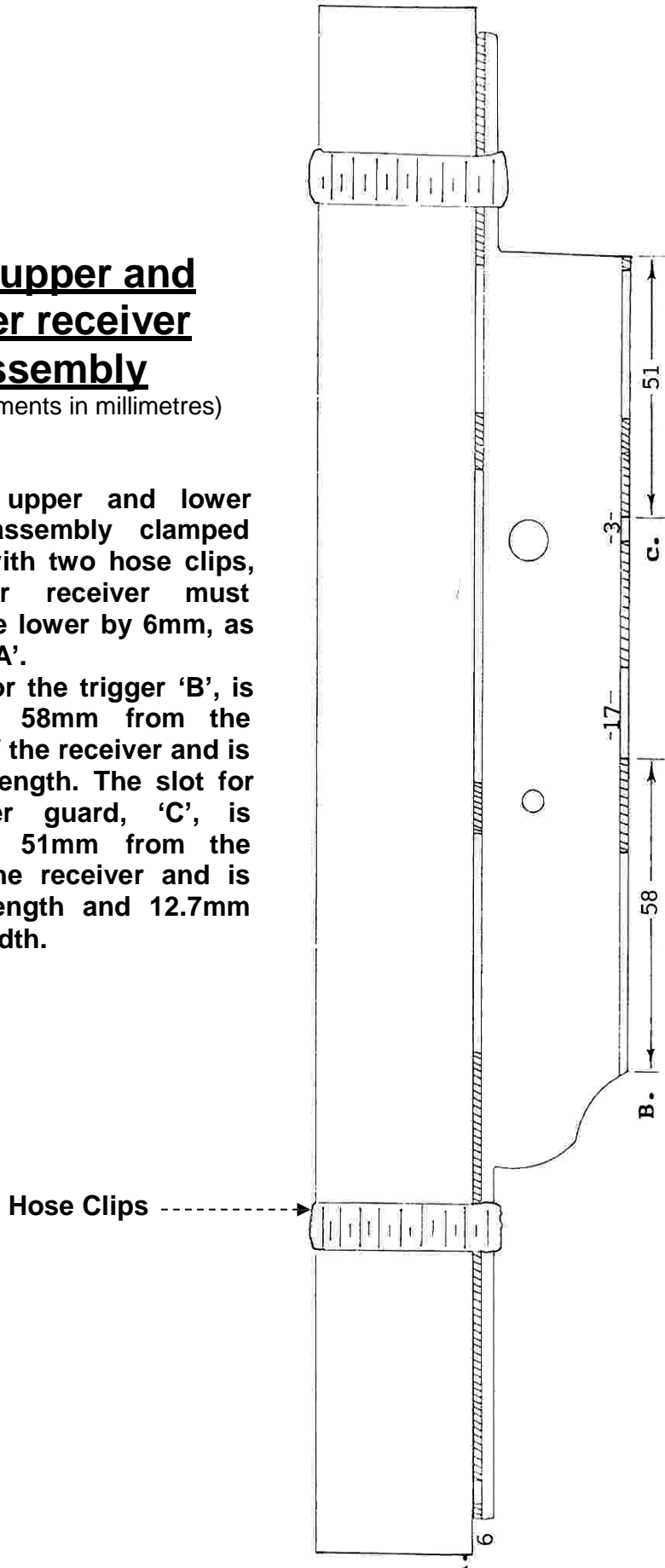

LOWER RECEIVER ASSEMBLY

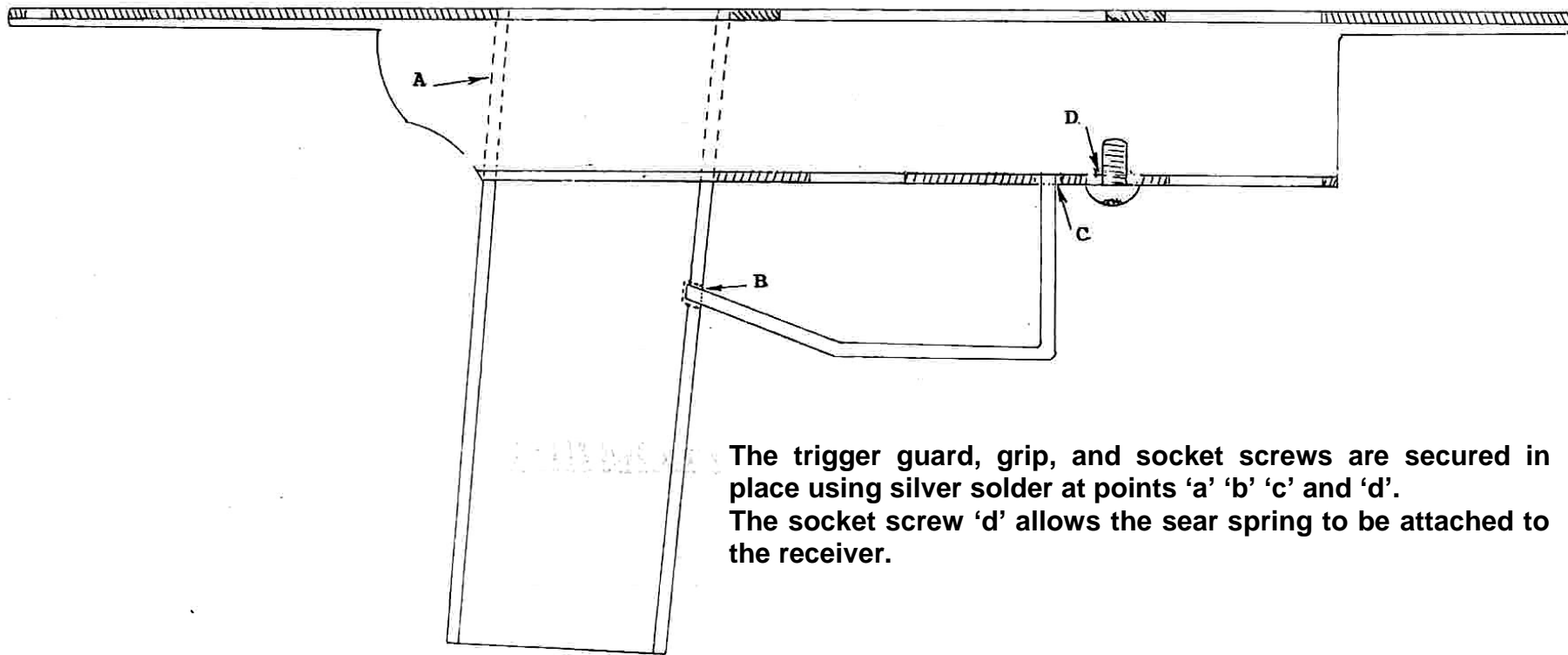

The trigger guard, grip, and socket screws are secured in place using silver solder at points 'a' 'b' 'c' and 'd'. The socket screw 'd' allows the sear spring to be attached to the receiver.

TEMPLATES

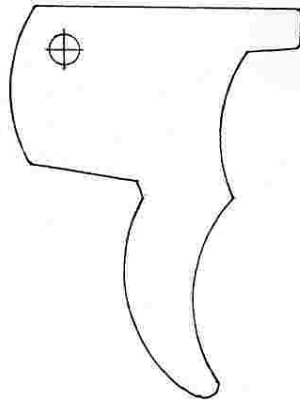

Trigger
(Steel plate)

Trigger guard
1/2 x 1/8"
Flat bar

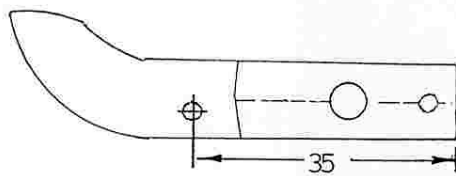
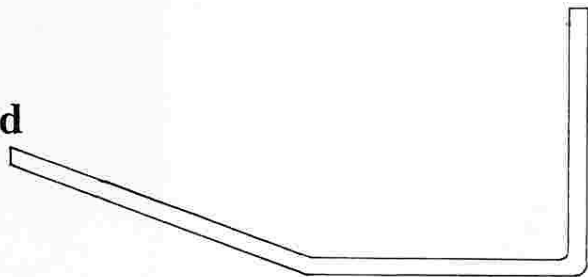

Sear
(Hexagonal key)

FULLY ASSEMBLED LOWER RECEIVER

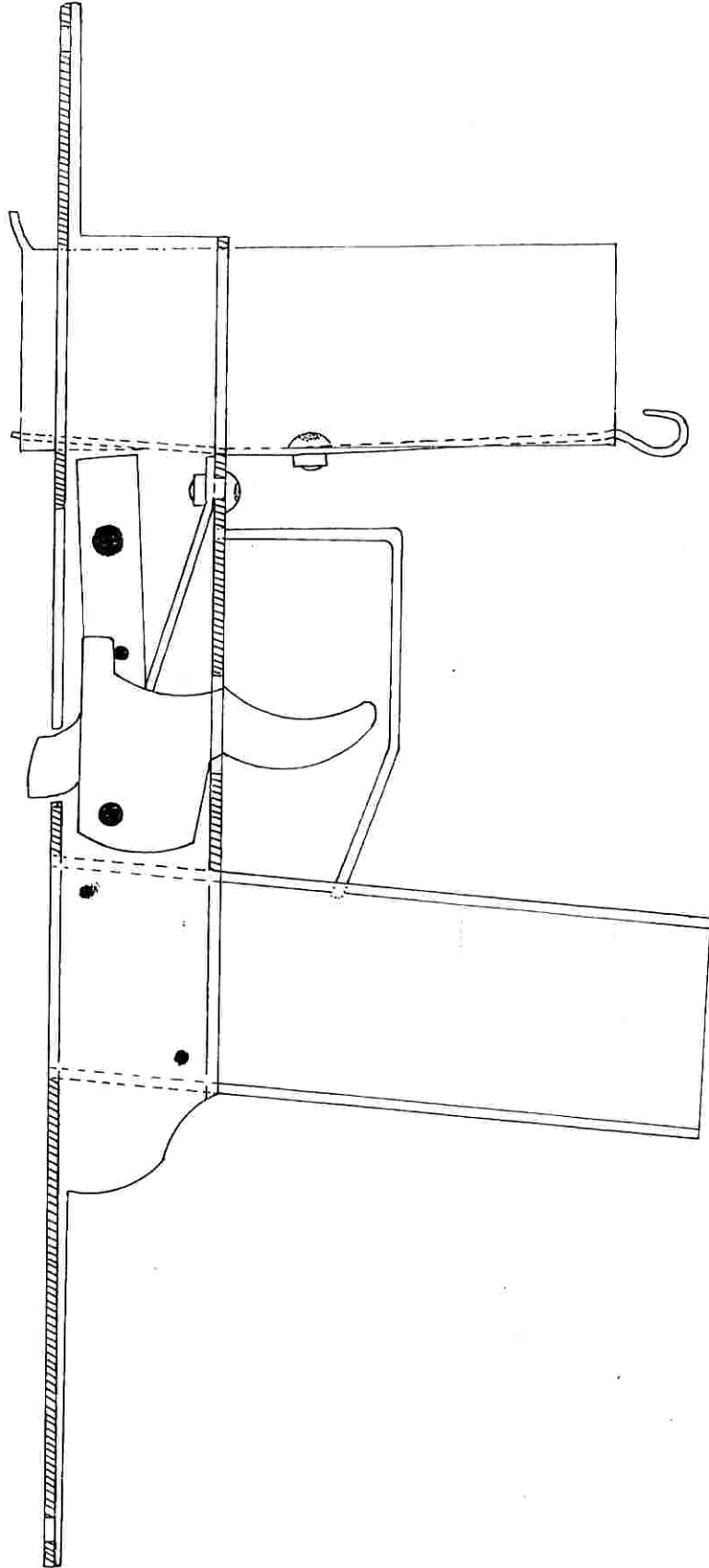

RECOIL SHIELD CONSTRUCTION

The recoil shield is machined from a section of steel bar to the following dimensions.

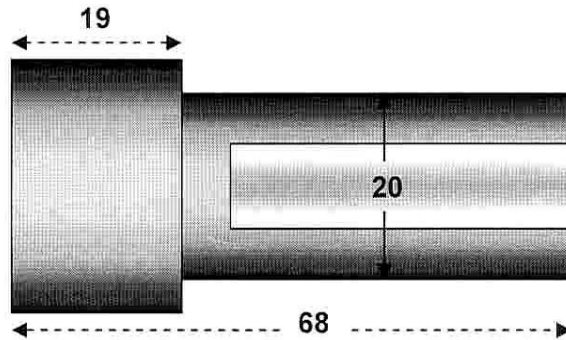

(Measurements in millimetres)

Following machining the recoil shield should look like the one illustrated below.

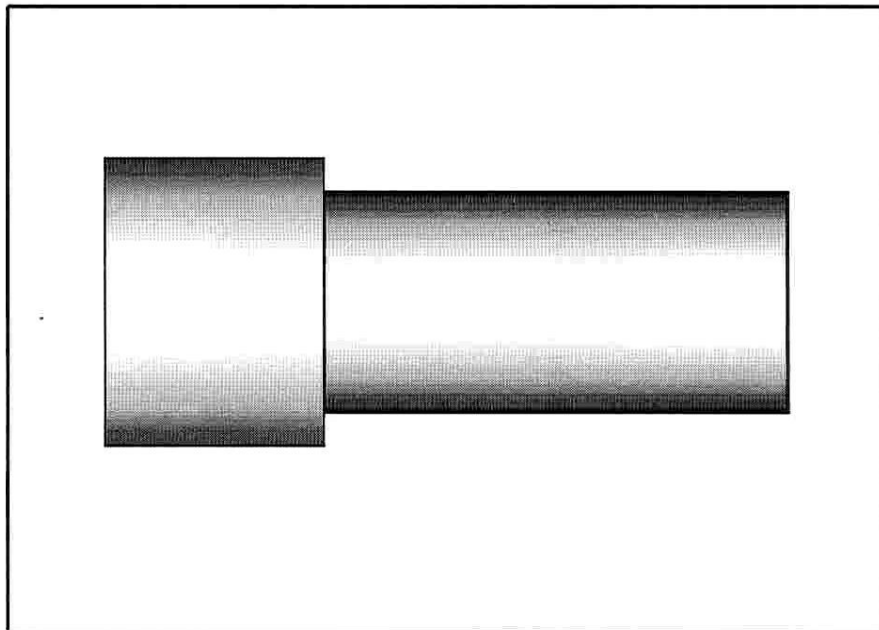

BOLT ASSEMBLY

A.

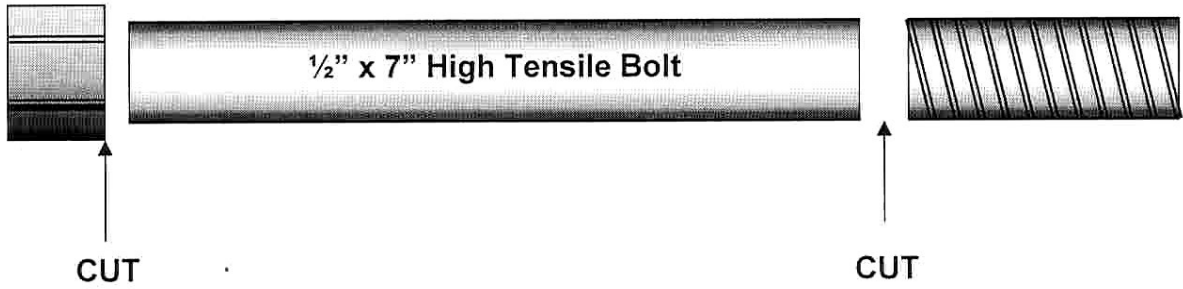

The bolt section is cut to an overall length of 112mm.

B.

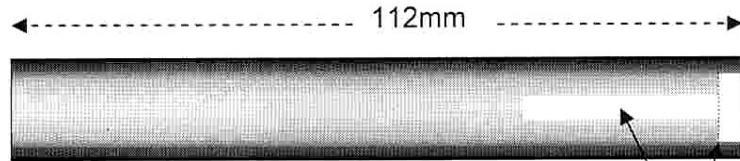

Cut cartridge recess and ejector slot.

C.

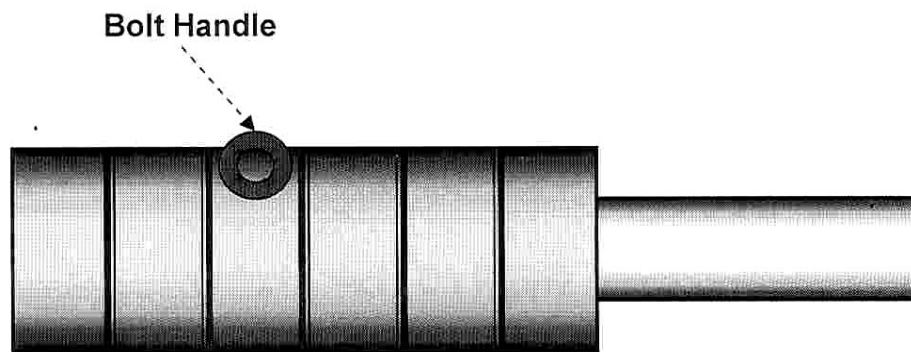

Fit six 1/2" collars and screw in bolt handle

.32/.380 Machine Pistol Mark II

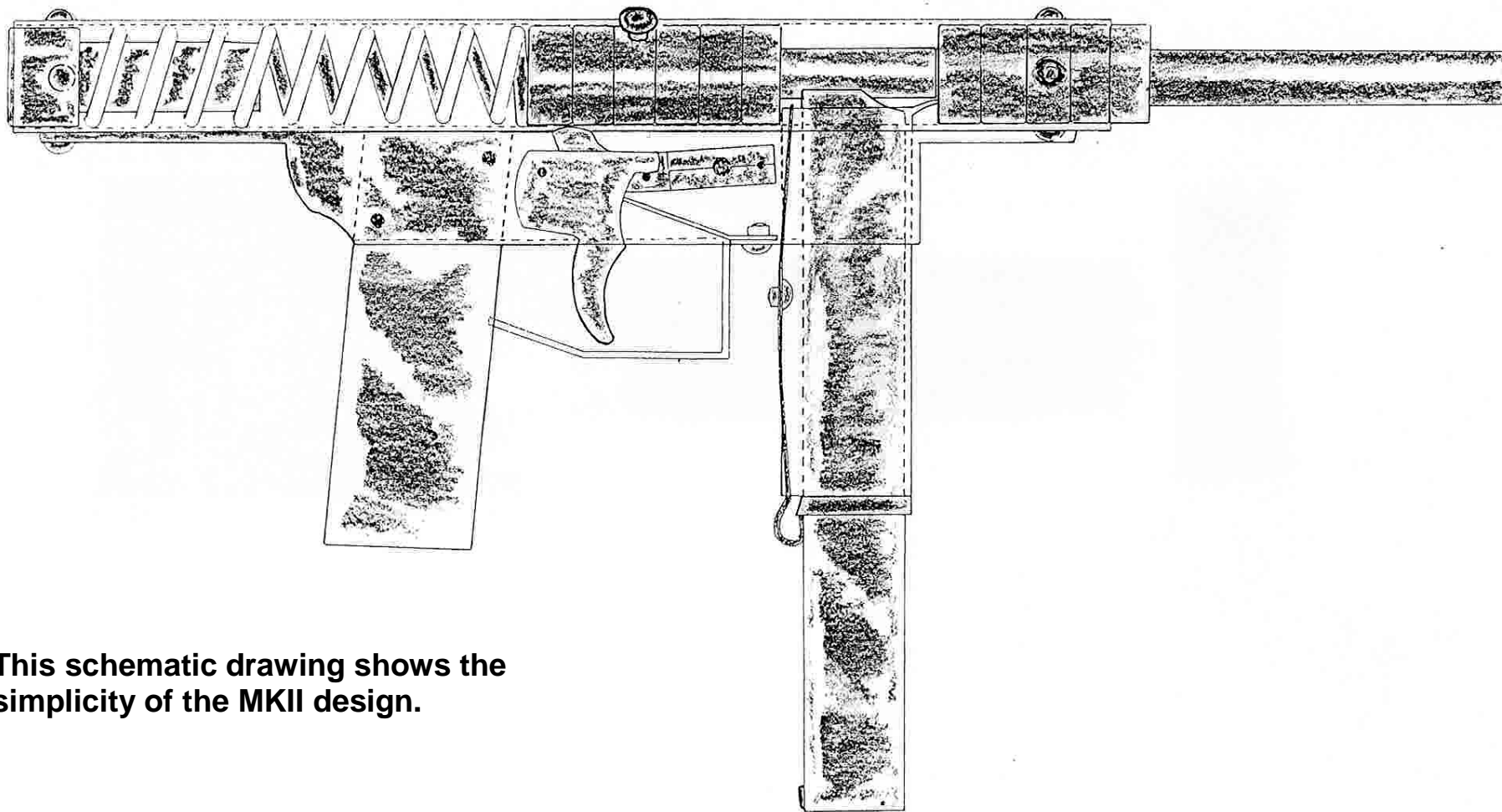

This schematic drawing shows the simplicity of the MKII design.

